

# SARJETA DE DESCARGA DIRECTA SIMPLES

Esc. 1/10

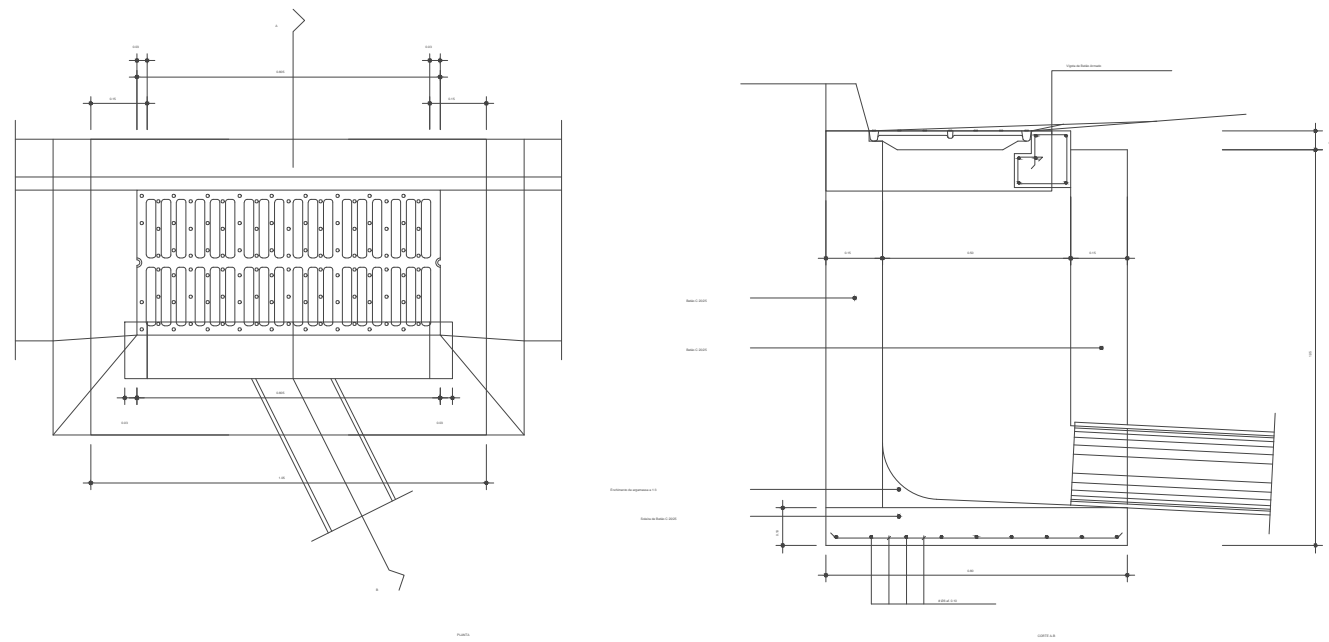

# CAIXA DE LIGAÇÃO AO COLECTOR

Esc. 1/20

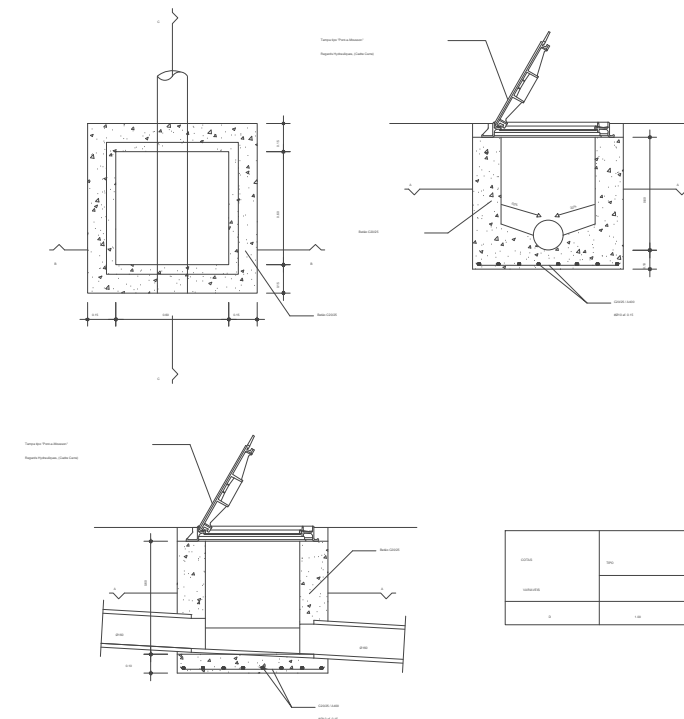

# VALA PARA 1 COLECTOR

Esc. 1/10

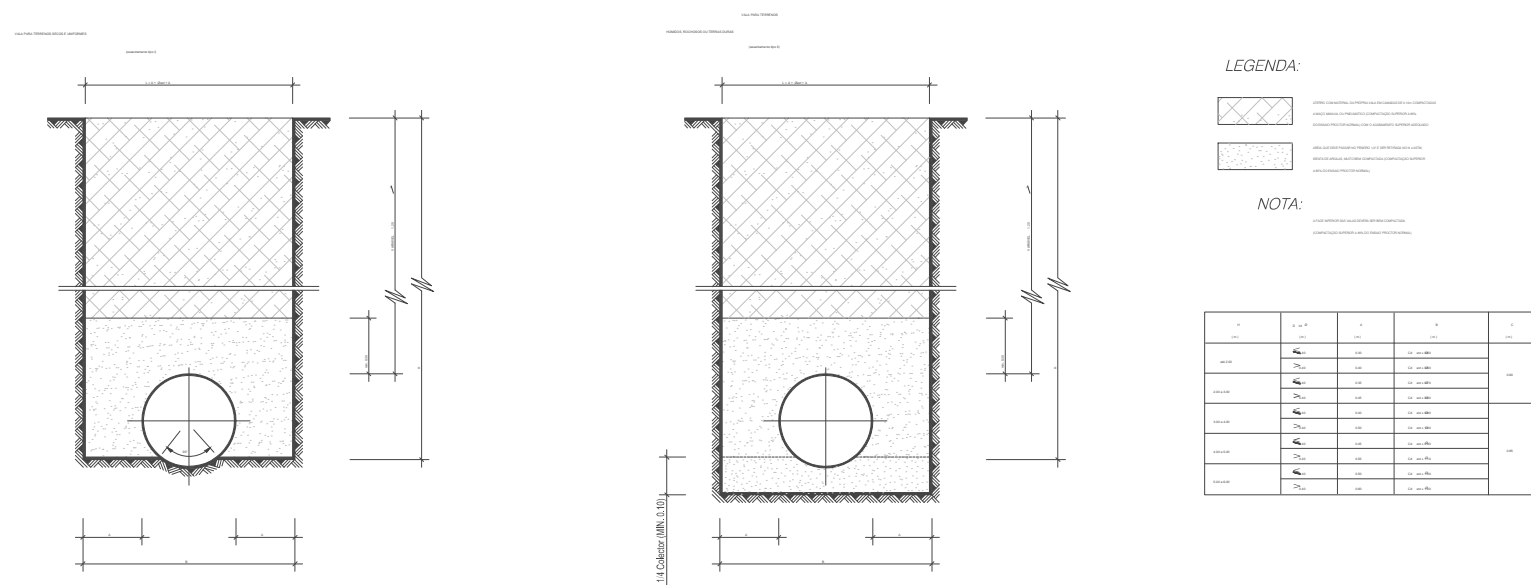

# PORMENOR CONSTRUTIVO DA VALA DE DRENAGEM

Esc. 1/10

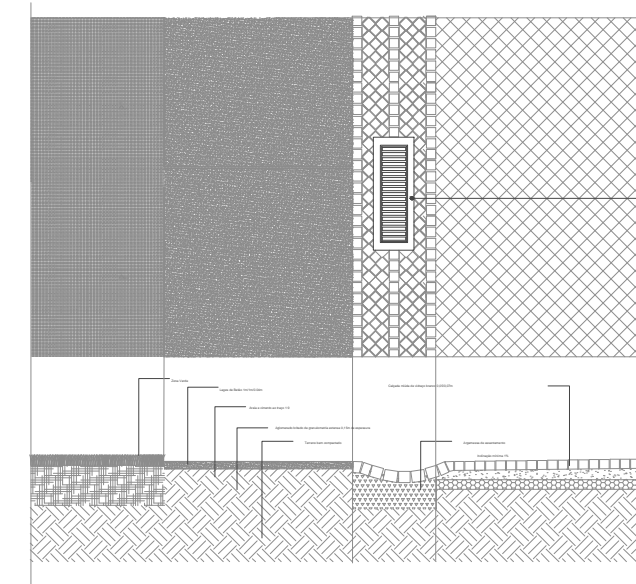

# PORMENOR CONSTRUTIVO DA ZONA DO RECREIO

Esc. 1/10

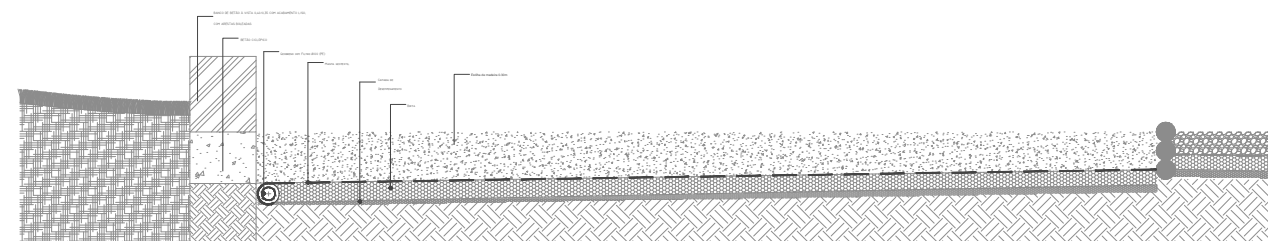

REGUALIFICAÇÃO DO ESPAÇO EXTERIOR

