

PERSPECTIVA OBLÍQUA

Maria do Céu s. Tereno - 2011

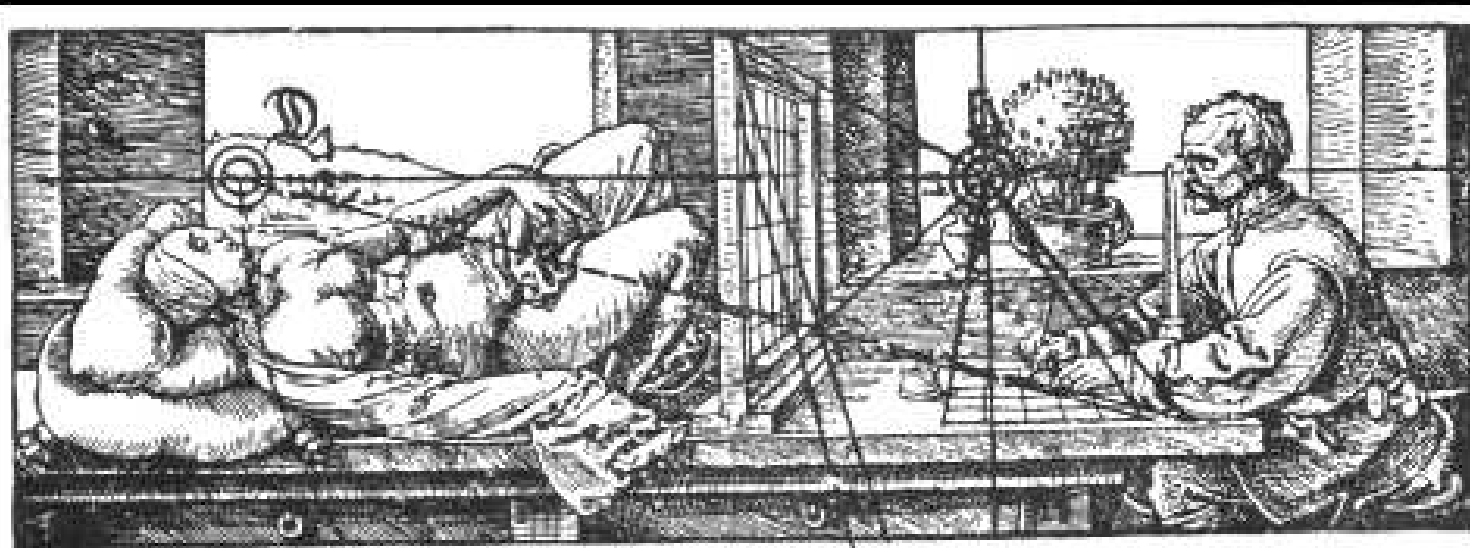

A. DÜRER. „Der Zeichner des liegenden Weibes.“ U. d. M. 1538. 21,5 x 7,5†

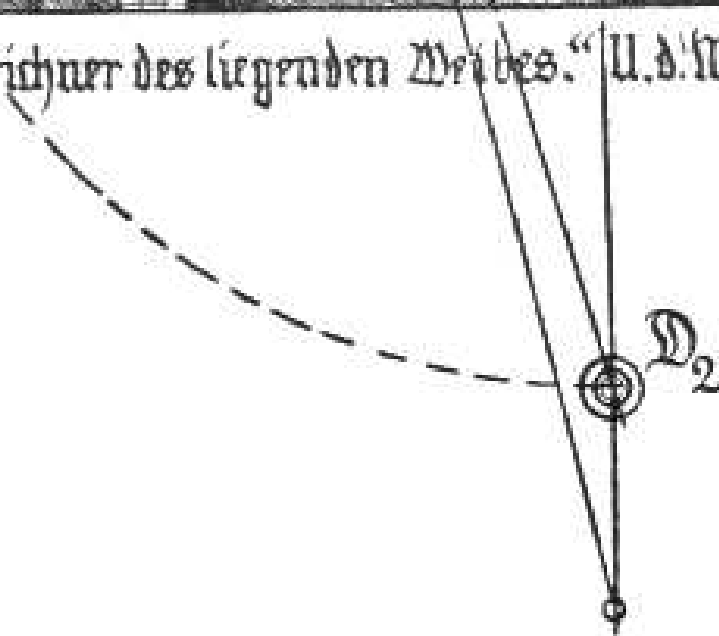

PERSPECTIVA OBLÍQUA

Perspectiva Cónica Oblíqua - ou com dois pontos de fuga

Perspectiva cónica oblíqua

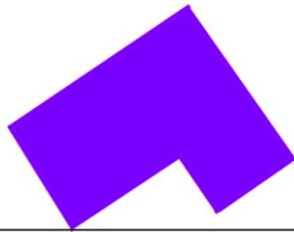

L.T. = L.H.

P.P.

Obs.

P.P.

L.H.

L.T.

Perspectiva cónica oblíqua

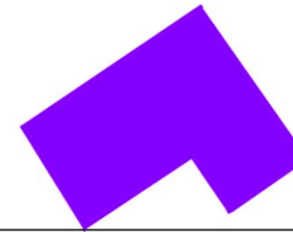

F1

L.T. = L.H.

F2

P.P.

Obs.

F1

P.P.

L.H.

F2

L.T.

PERSPECTIVA OBLÍQUA

Perspectiva cónica oblíqua

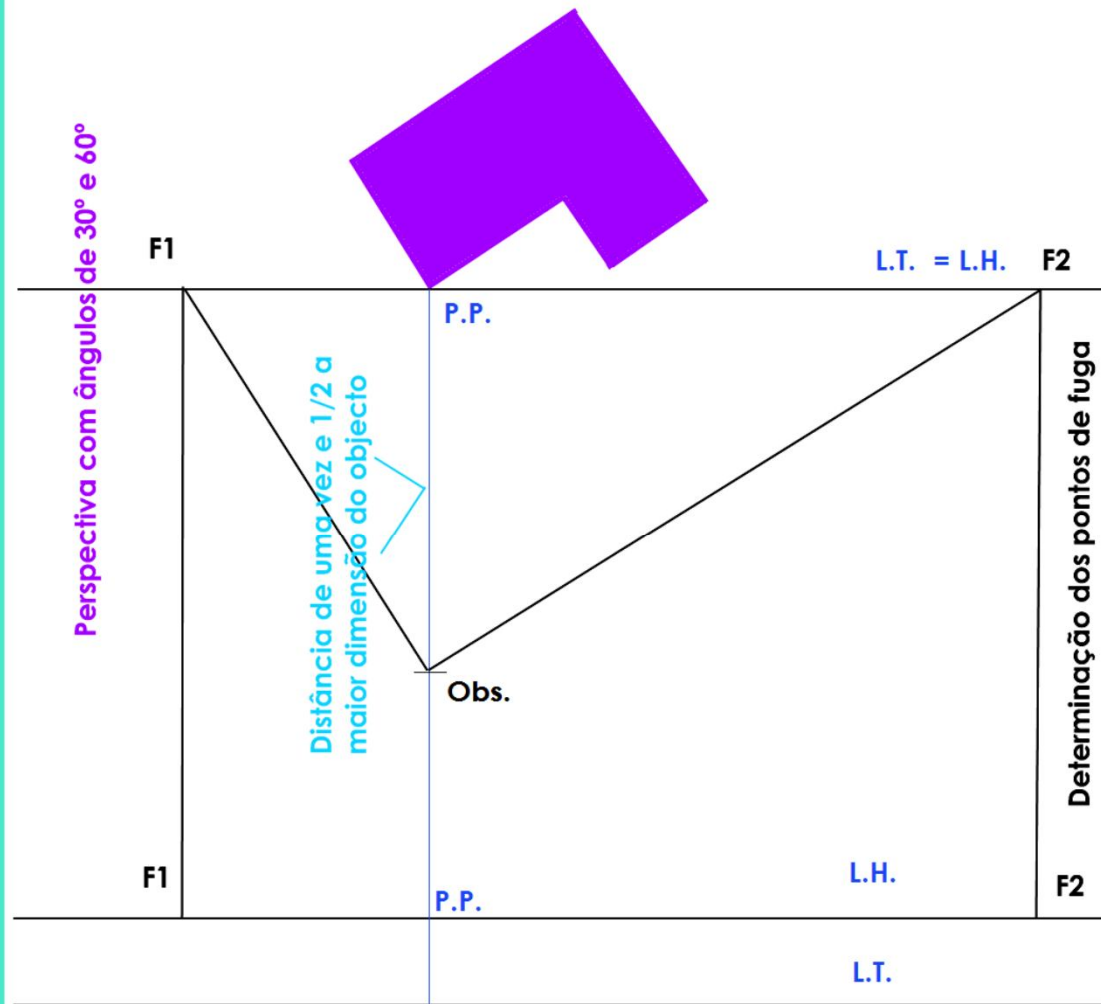

PERSPECTIVA OBLÍQUA

Perspectiva cónica oblíqua

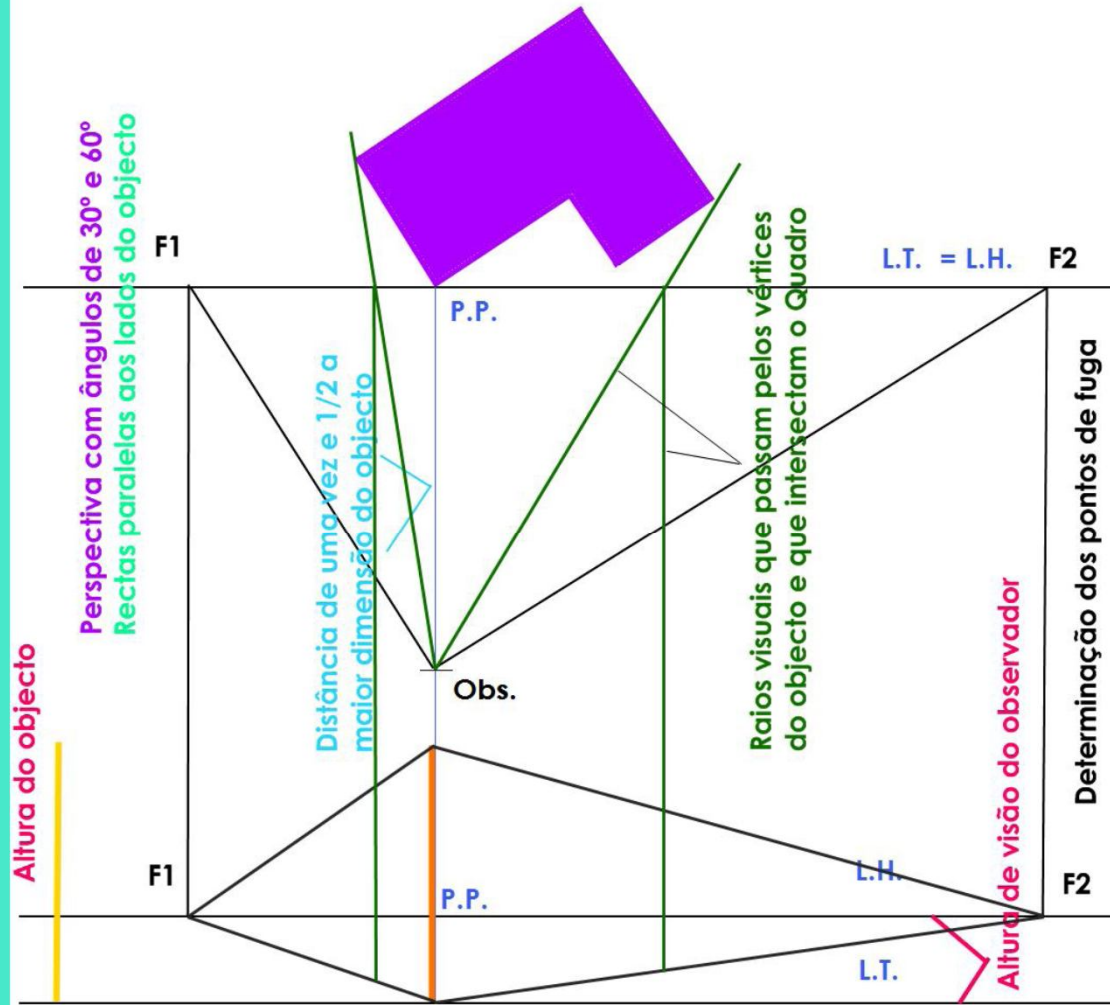

PERSPECTIVA OBLÍQUA

Perspectiva cónica oblíqua

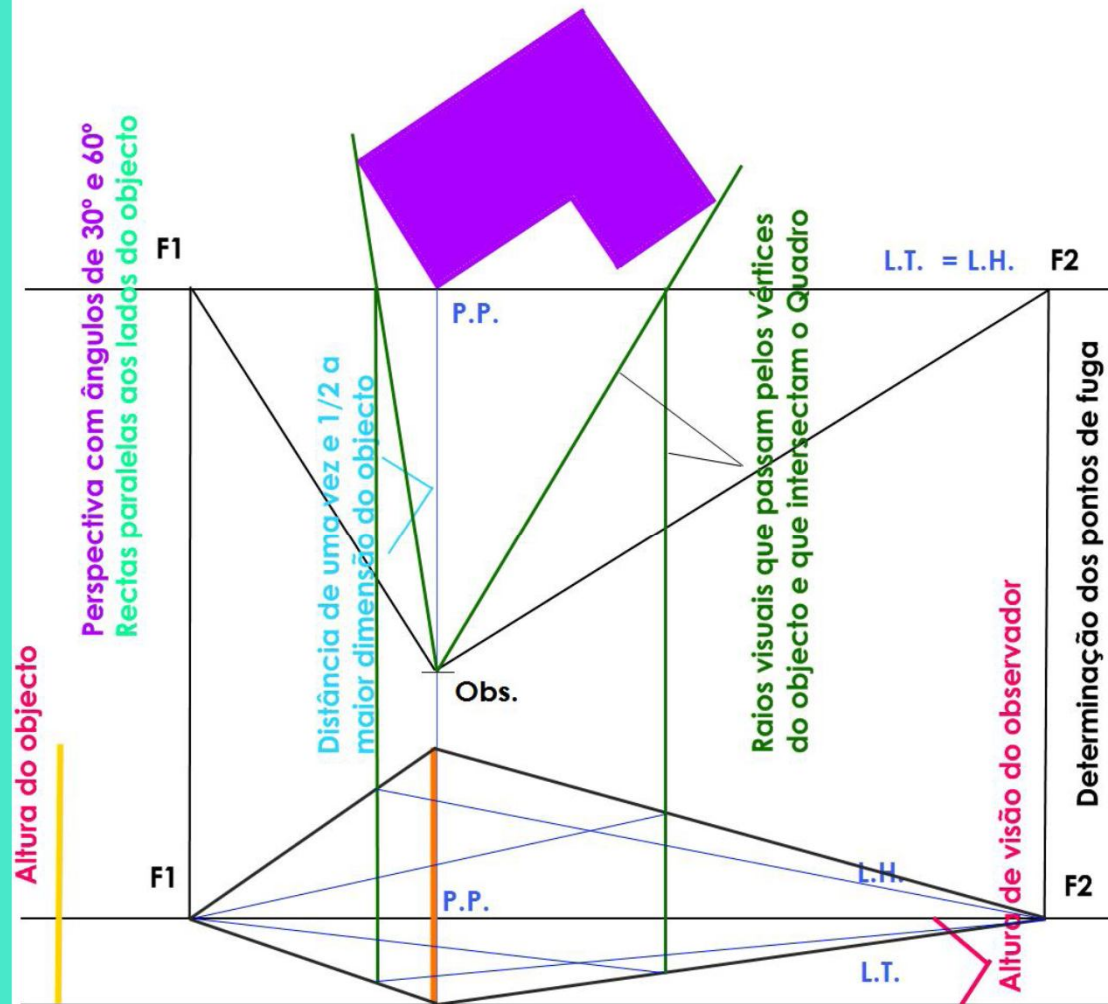

PERSPECTIVA OBLÍQUA

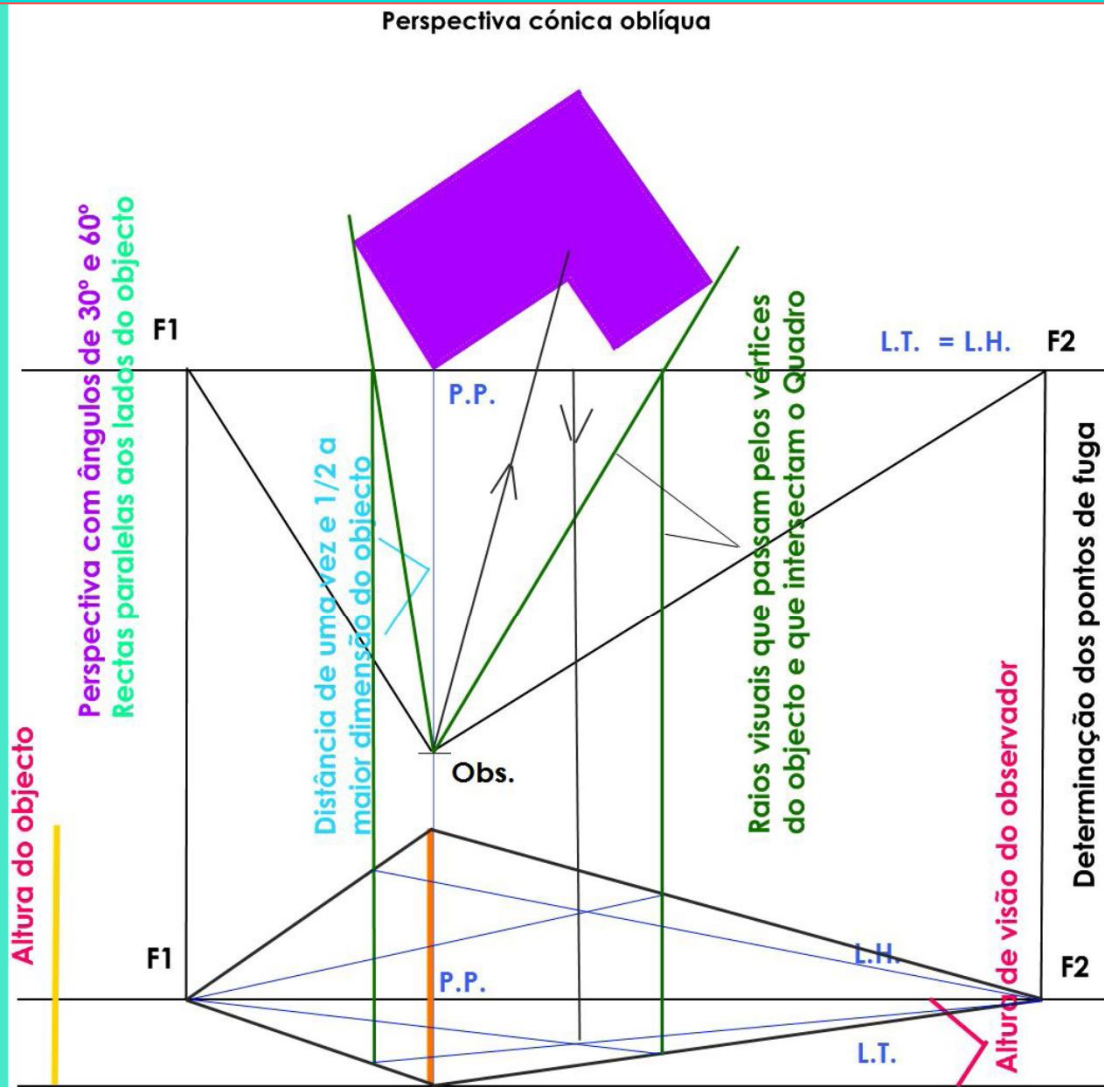

PERSPECTIVA OBLÍQUA

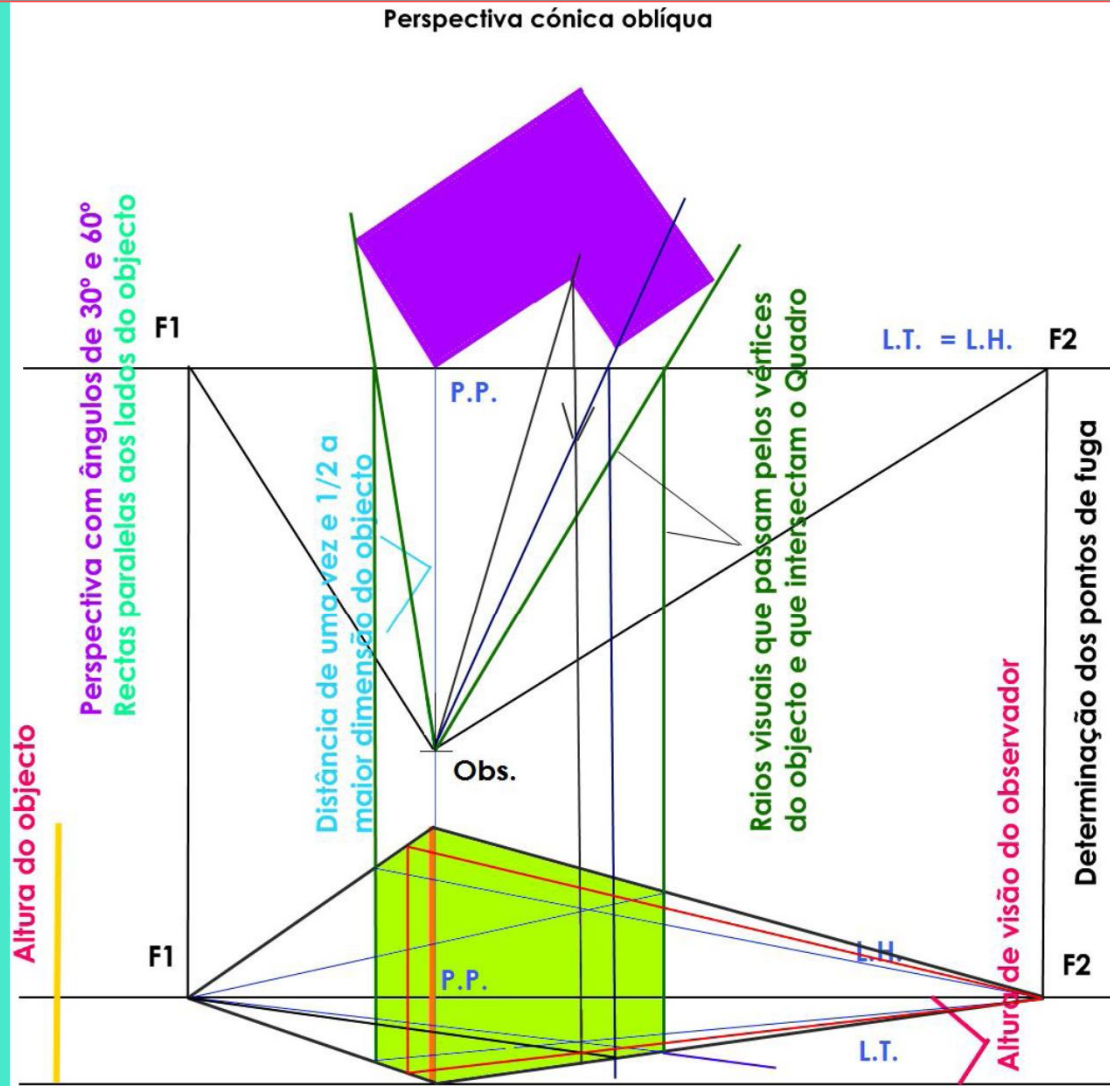

PERSPECTIVA OBLÍQUA

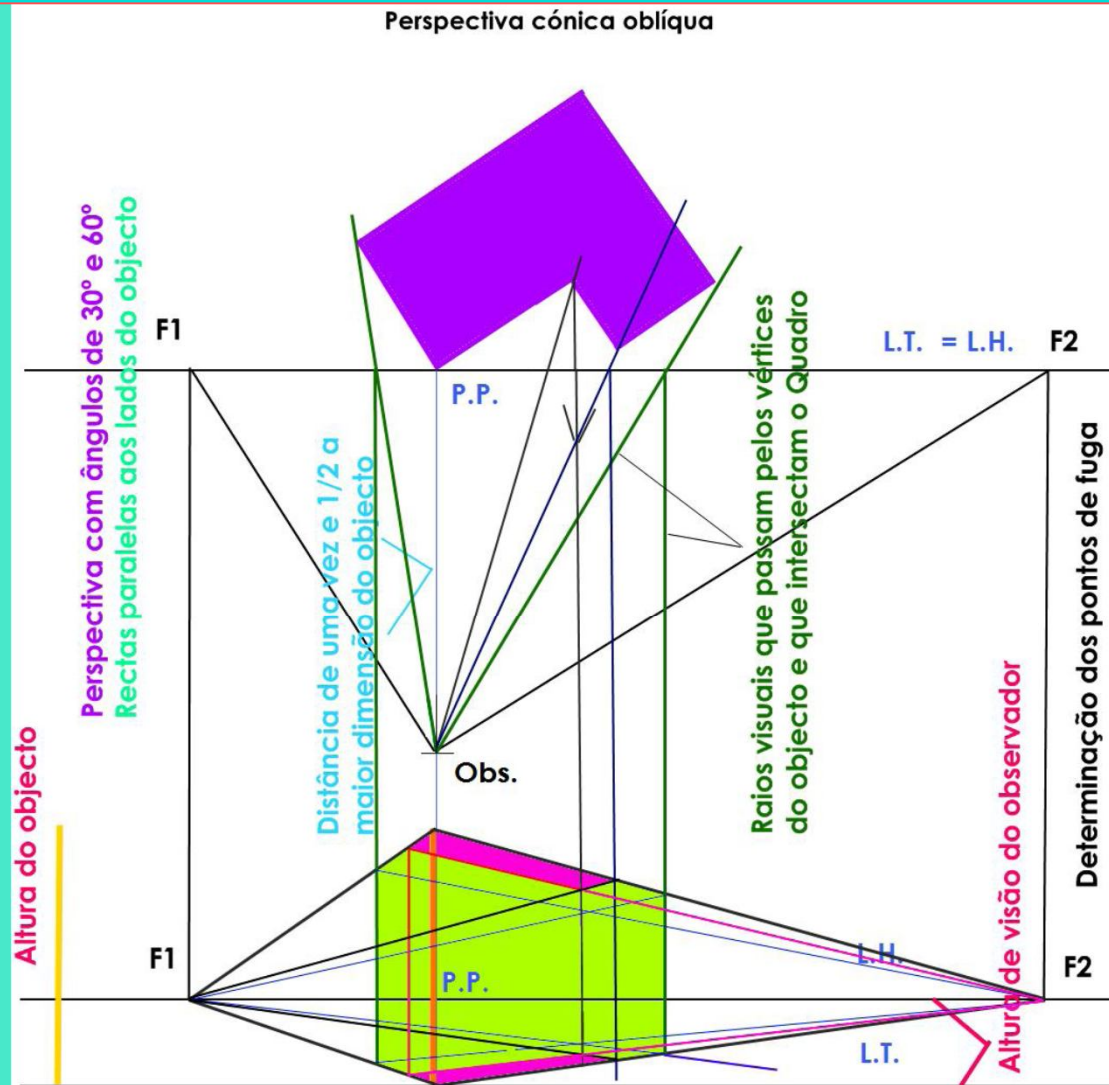

PERSPECTIVA OBLÍQUA

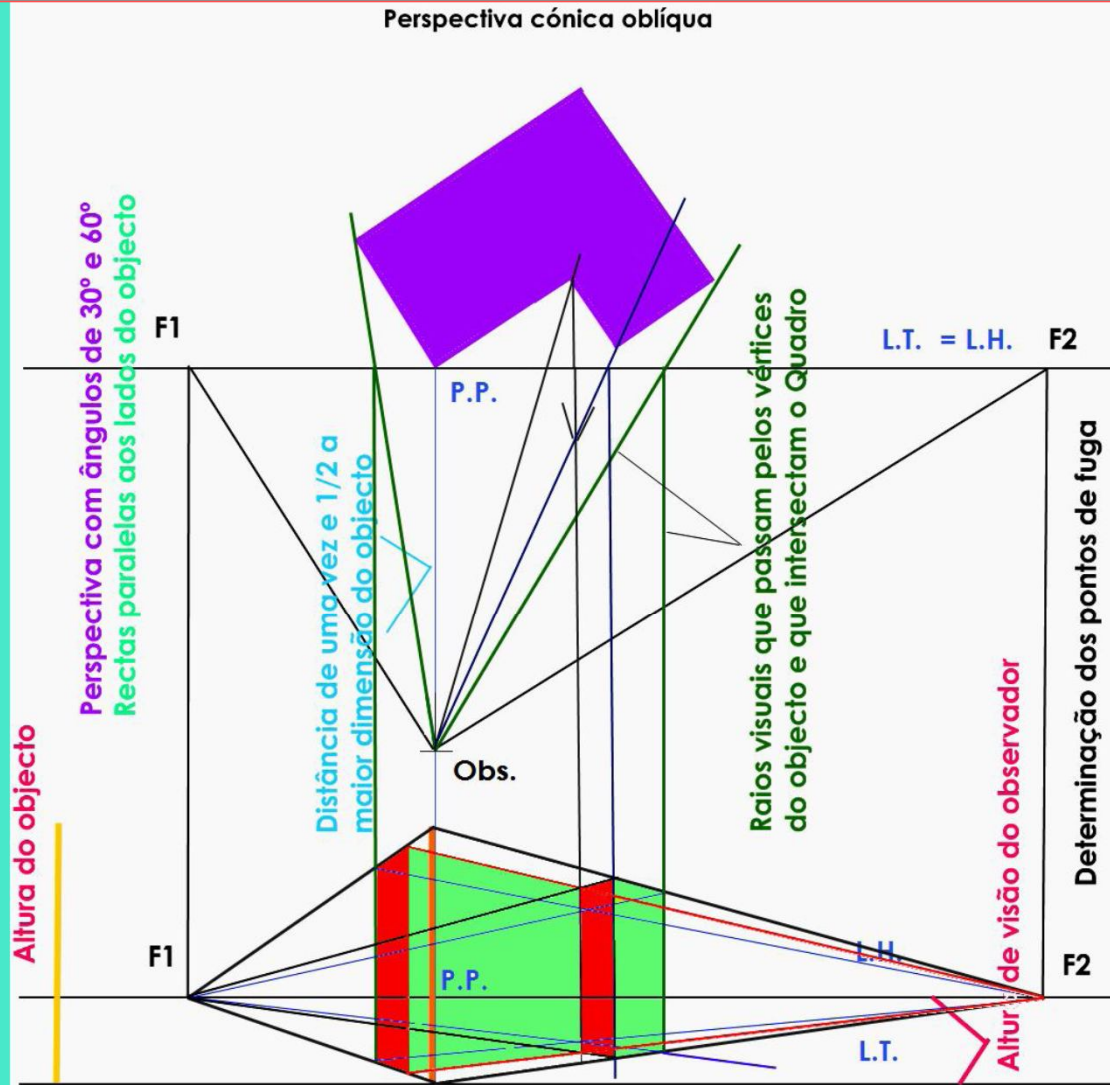

PERSPECTIVA OBLÍQUA

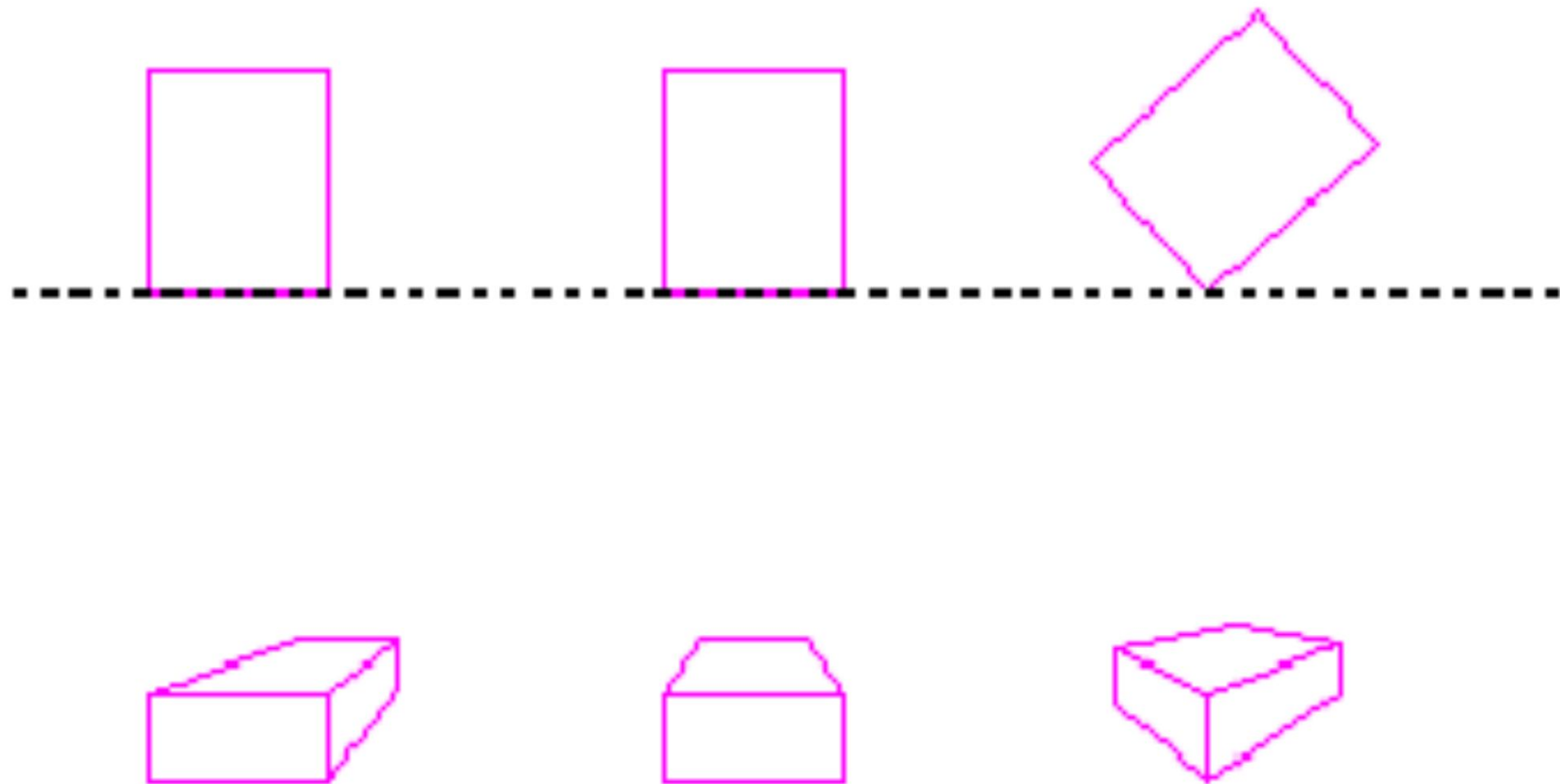

PERSPECTIVA OBLÍQUA

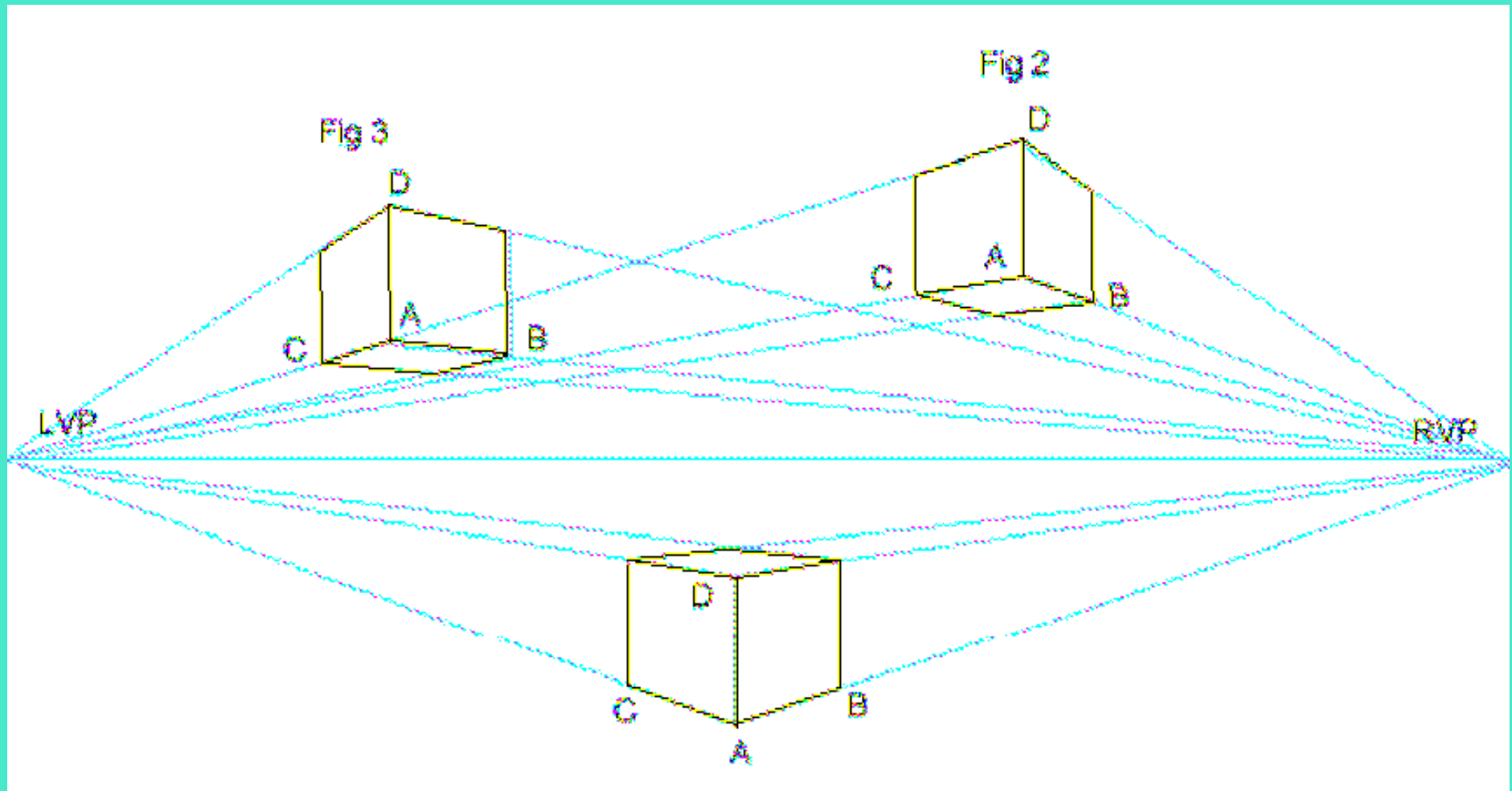

PERSPECTIVA OBLÍQUA

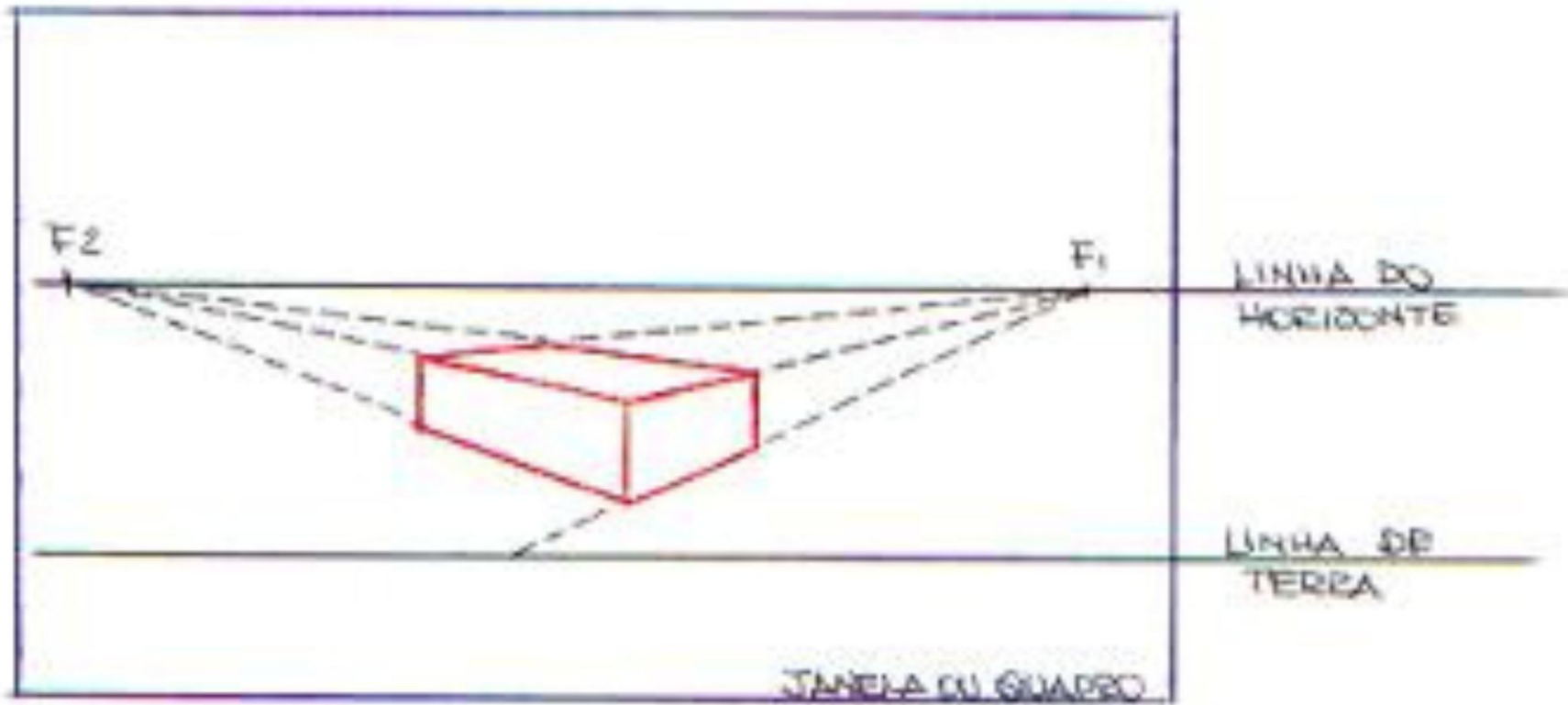

PERSPECTIVA OBLÍQUA

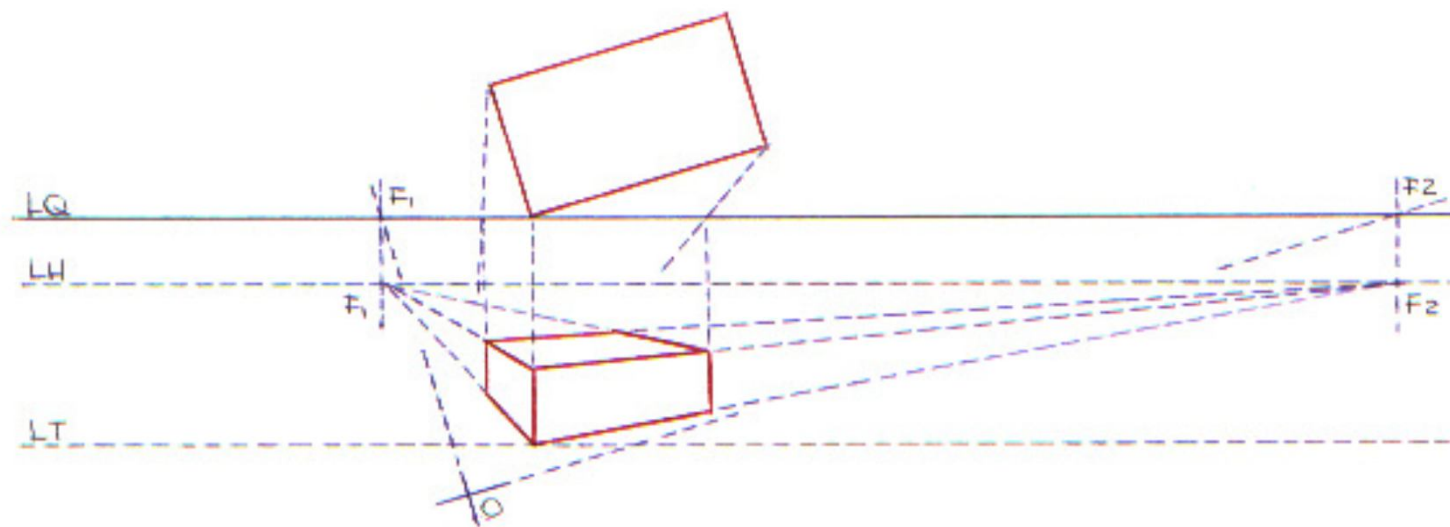
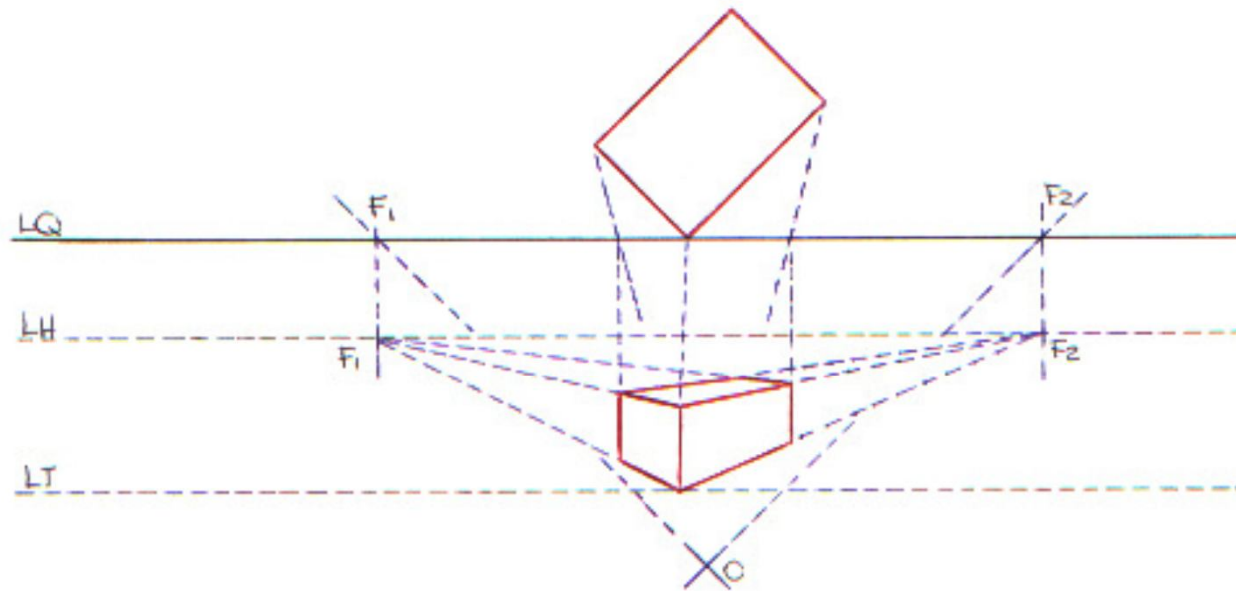

PERSPECTIVA OBLÍQUA

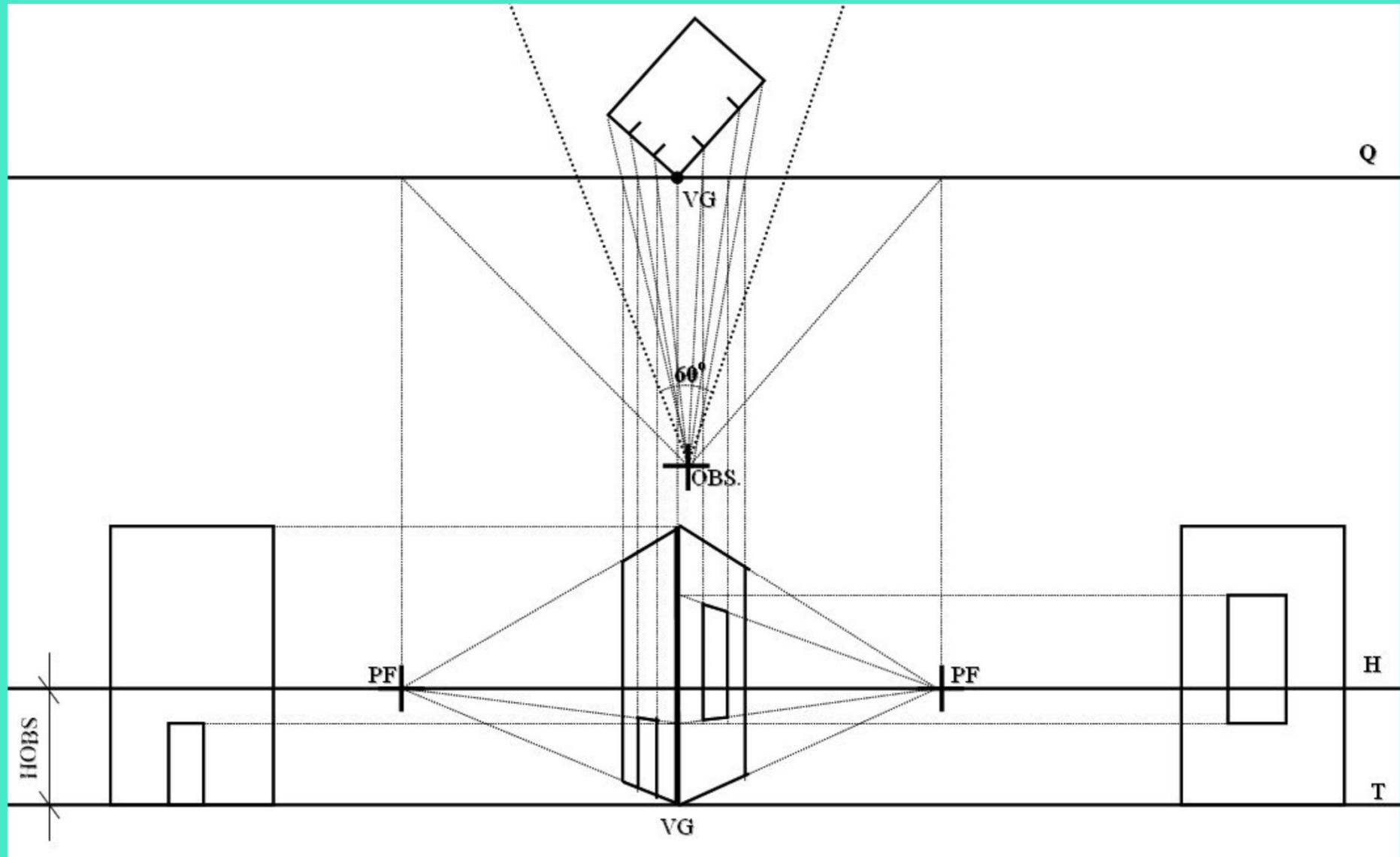

PERSPECTIVA OBLÍQUA



PERSPECTIVA OBLÍQUA

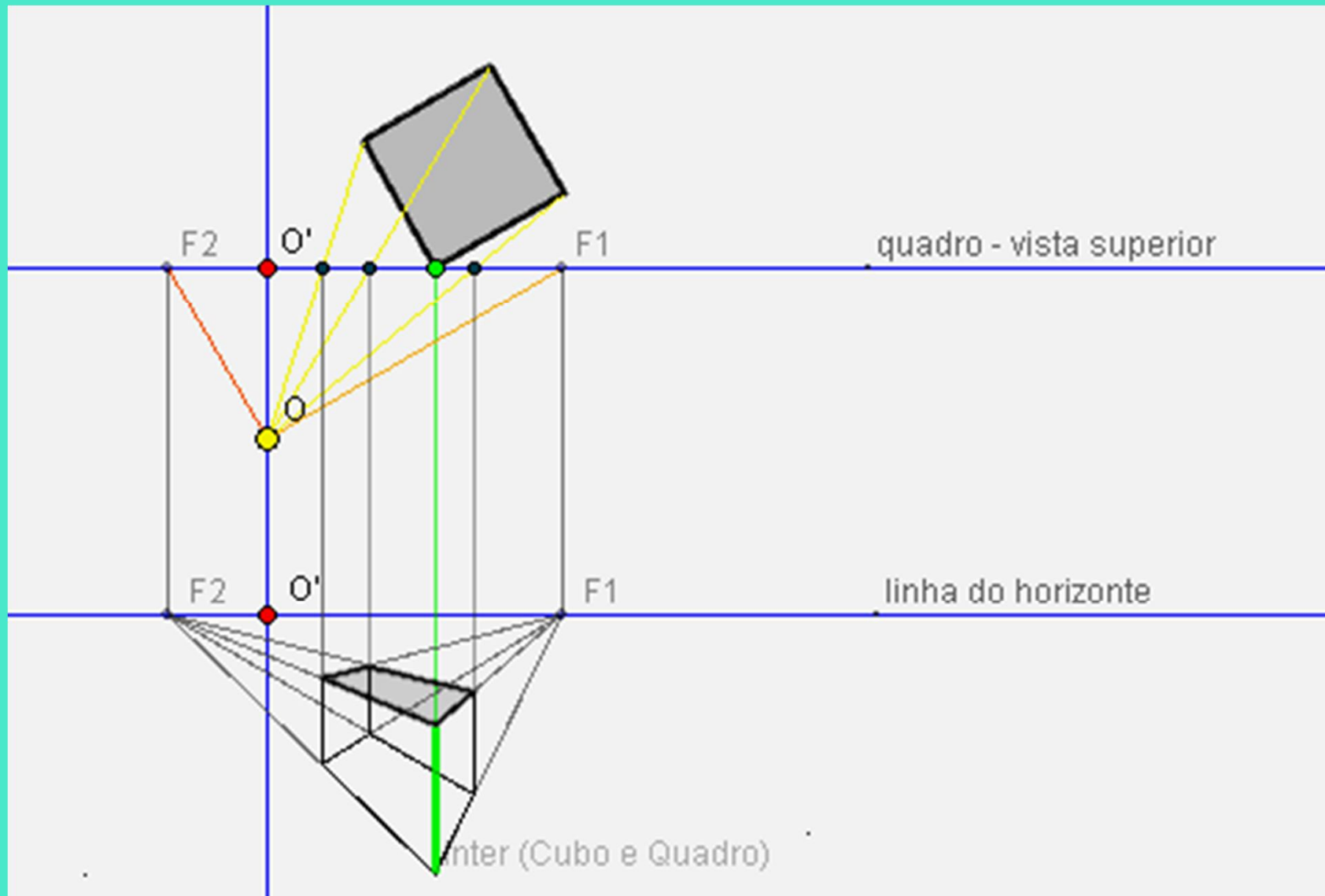

PERSPECTIVA OBLÍQUA

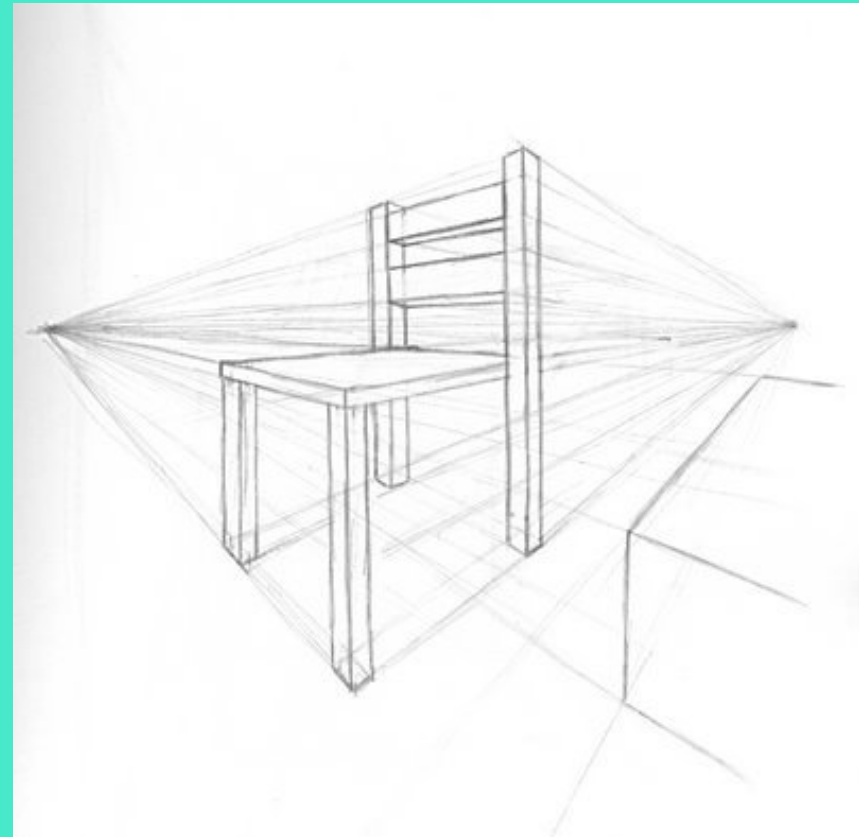
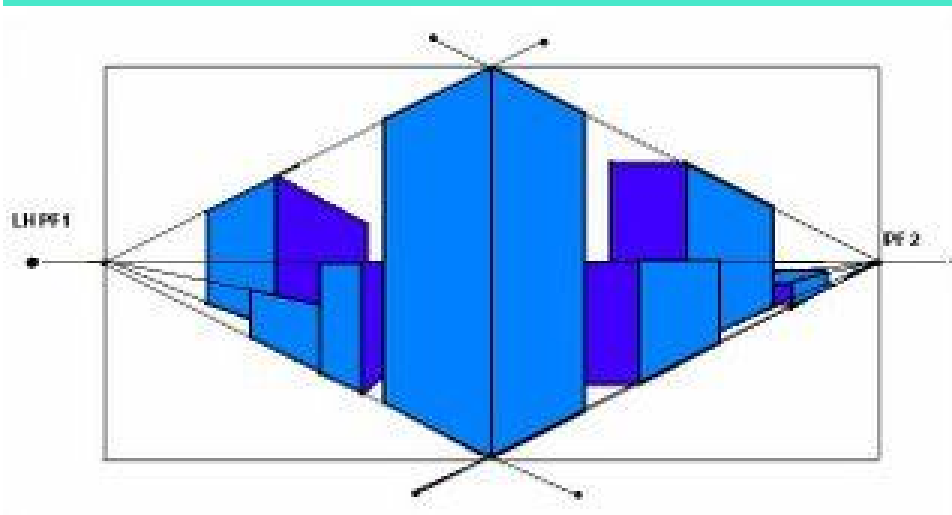

PERSPECTIVA OBLÍQUA

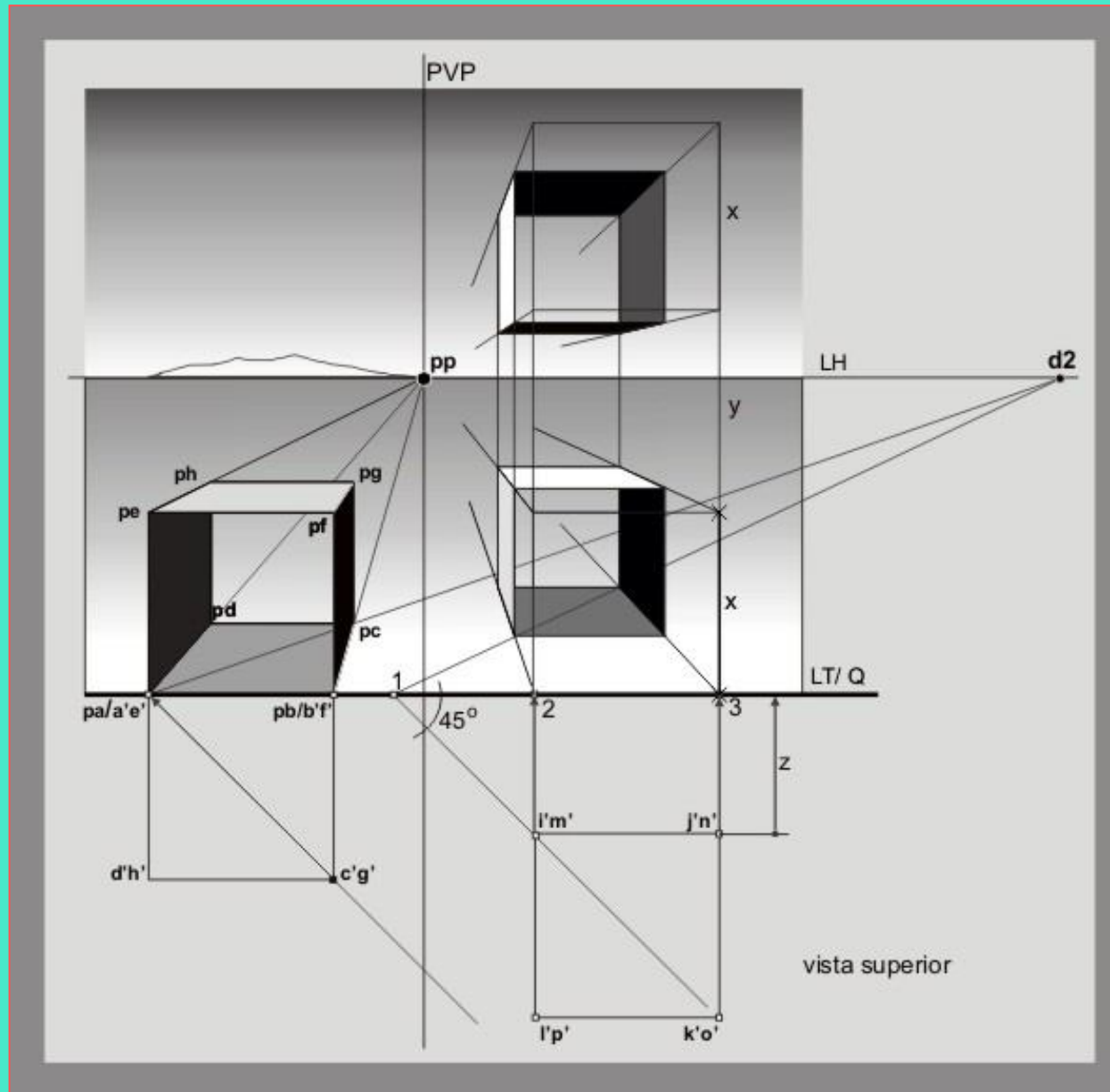

PERSPECTIVA OBLÍQUA

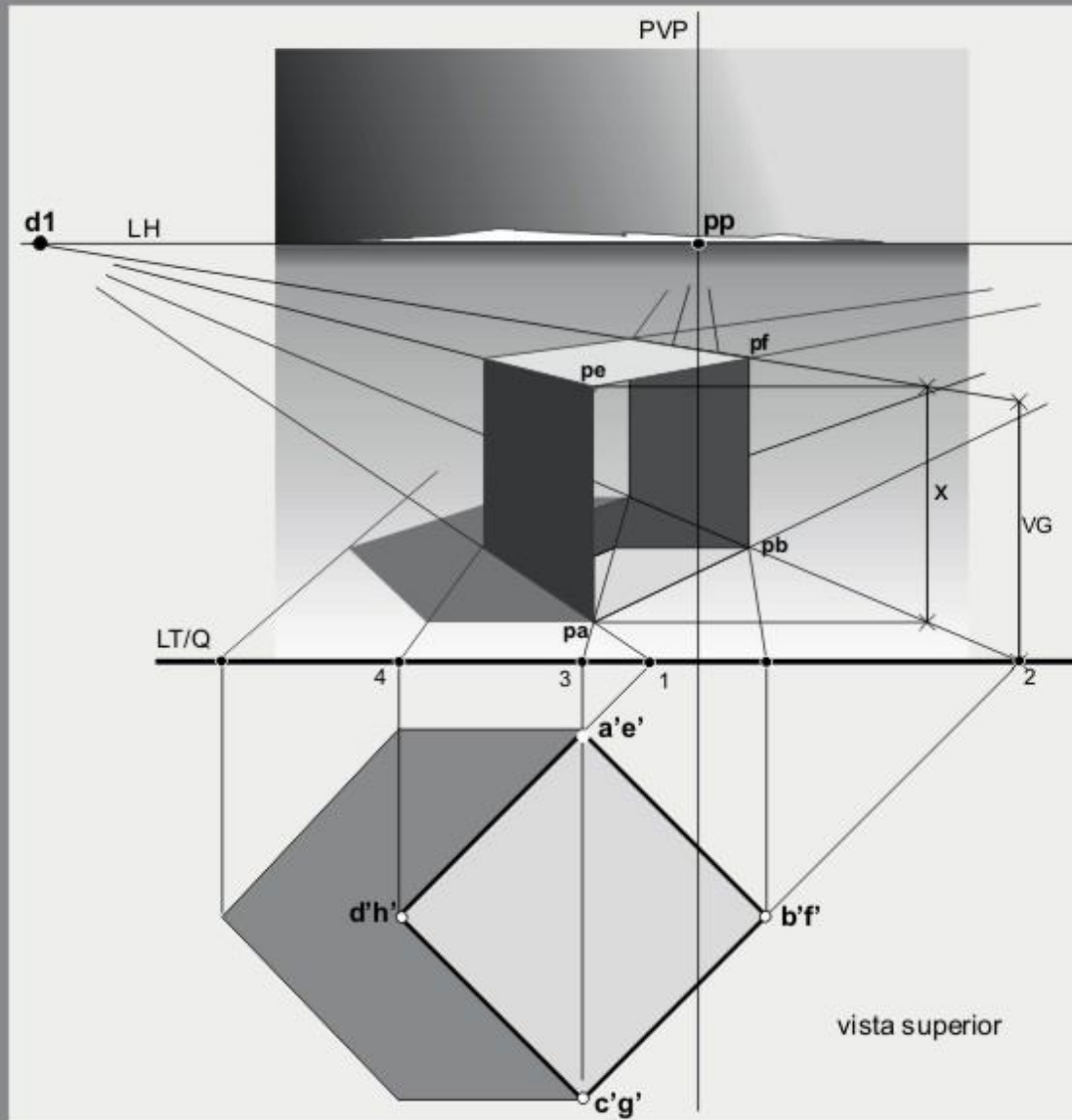

PERSPECTIVA OBLÍQUA

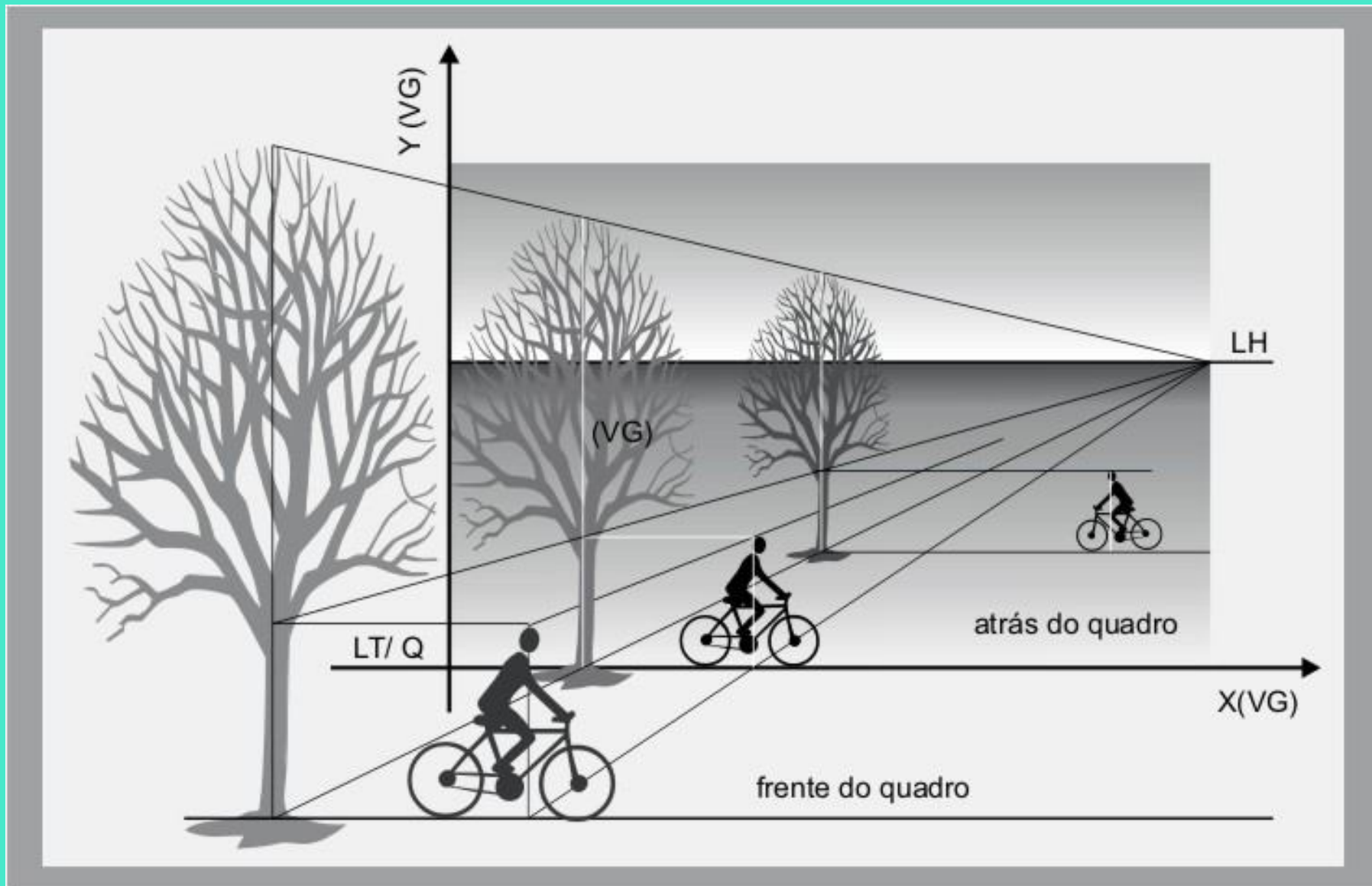

PERSPECTIVA OBLÍQUA

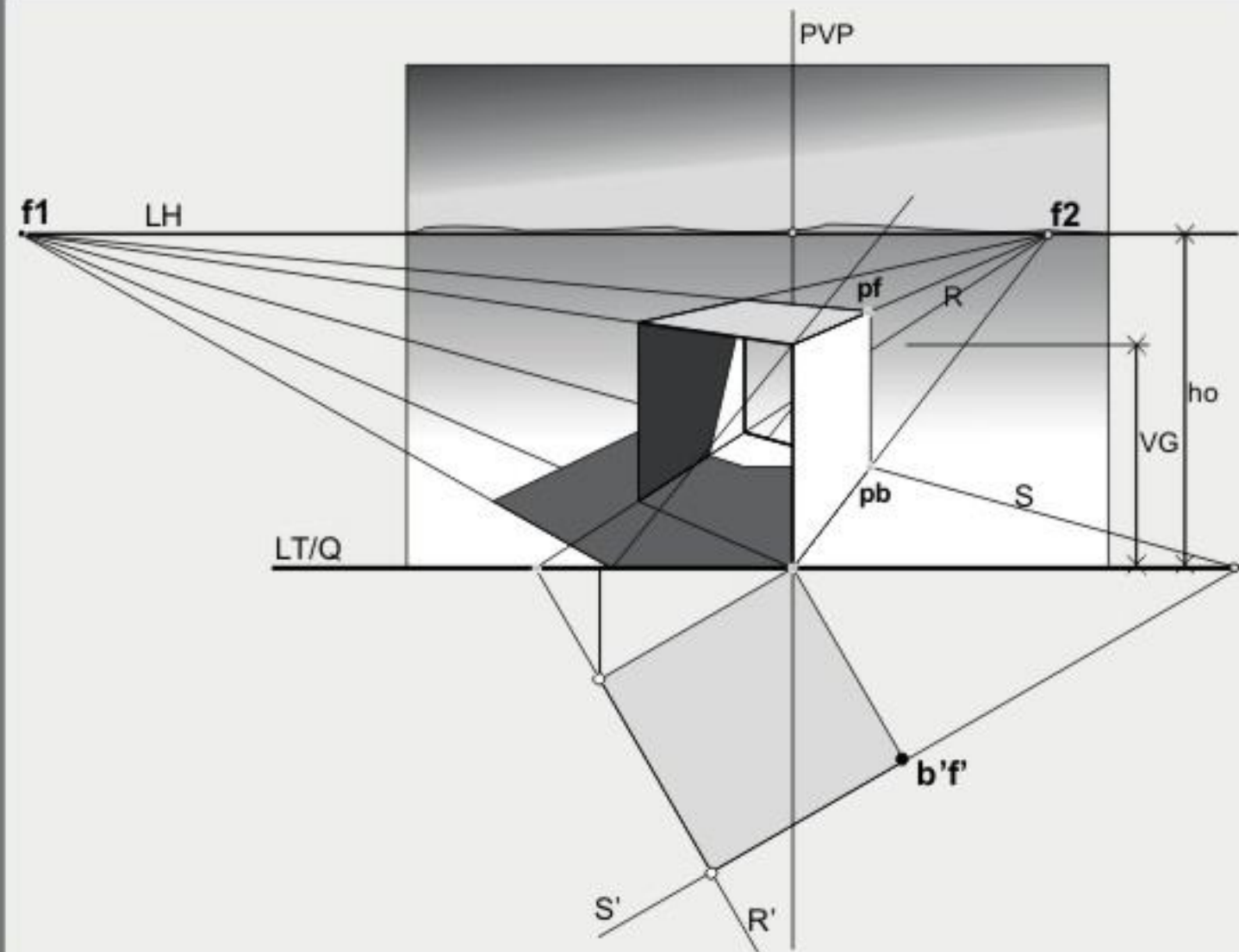

PERSPECTIVA OBLÍQUA

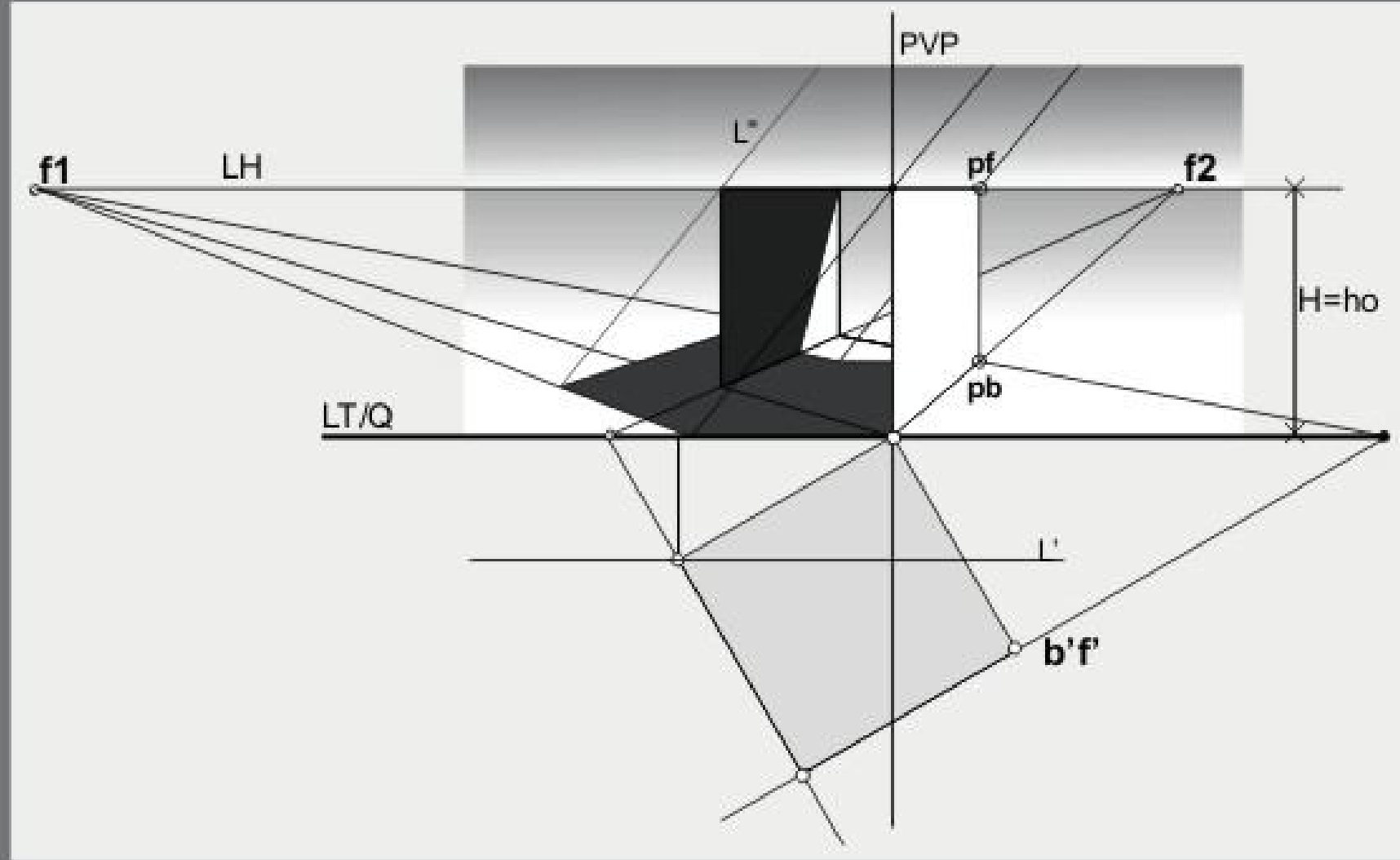

PERSPECTIVA OBLÍQUA

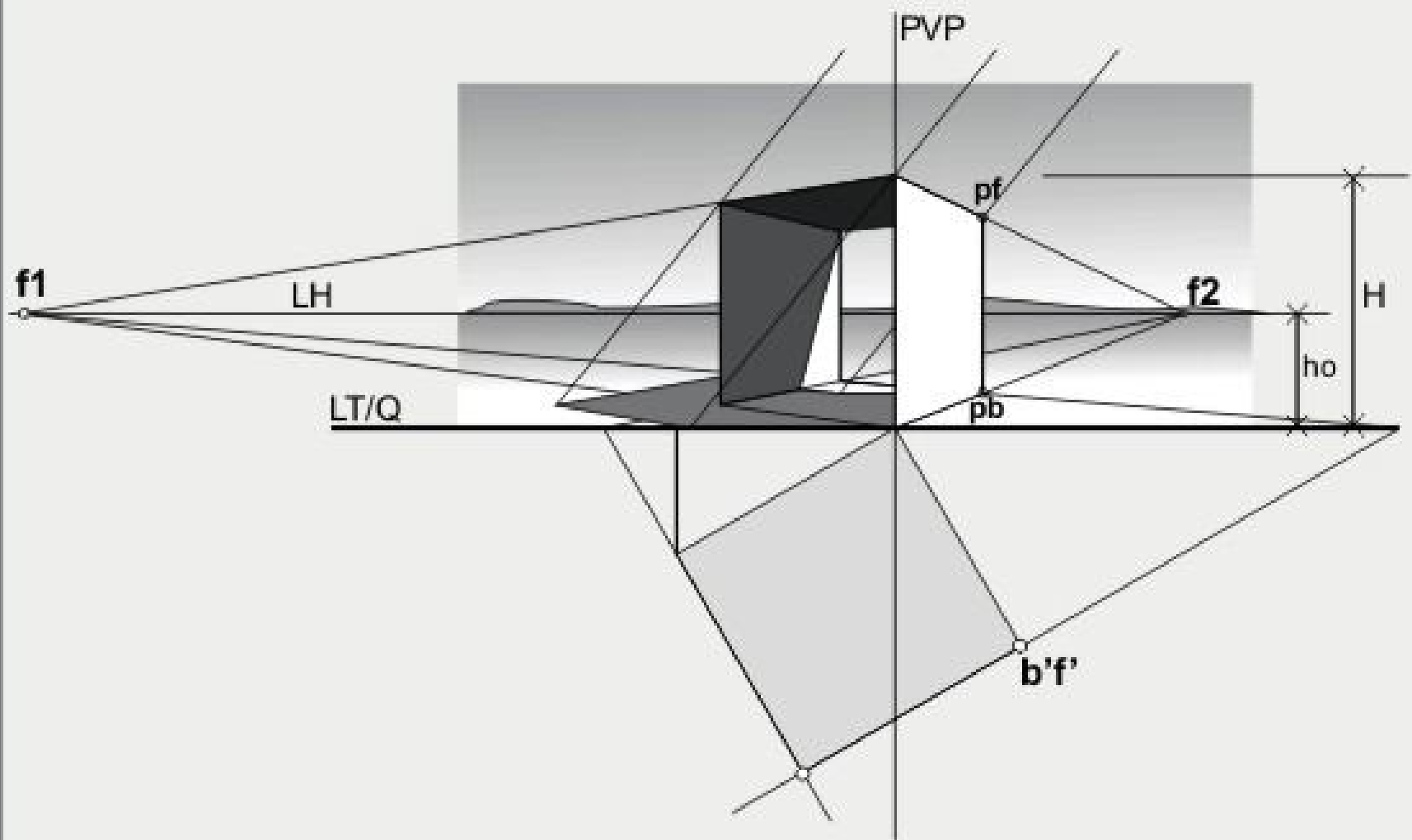

PERSPECTIVA OBLÍQUA

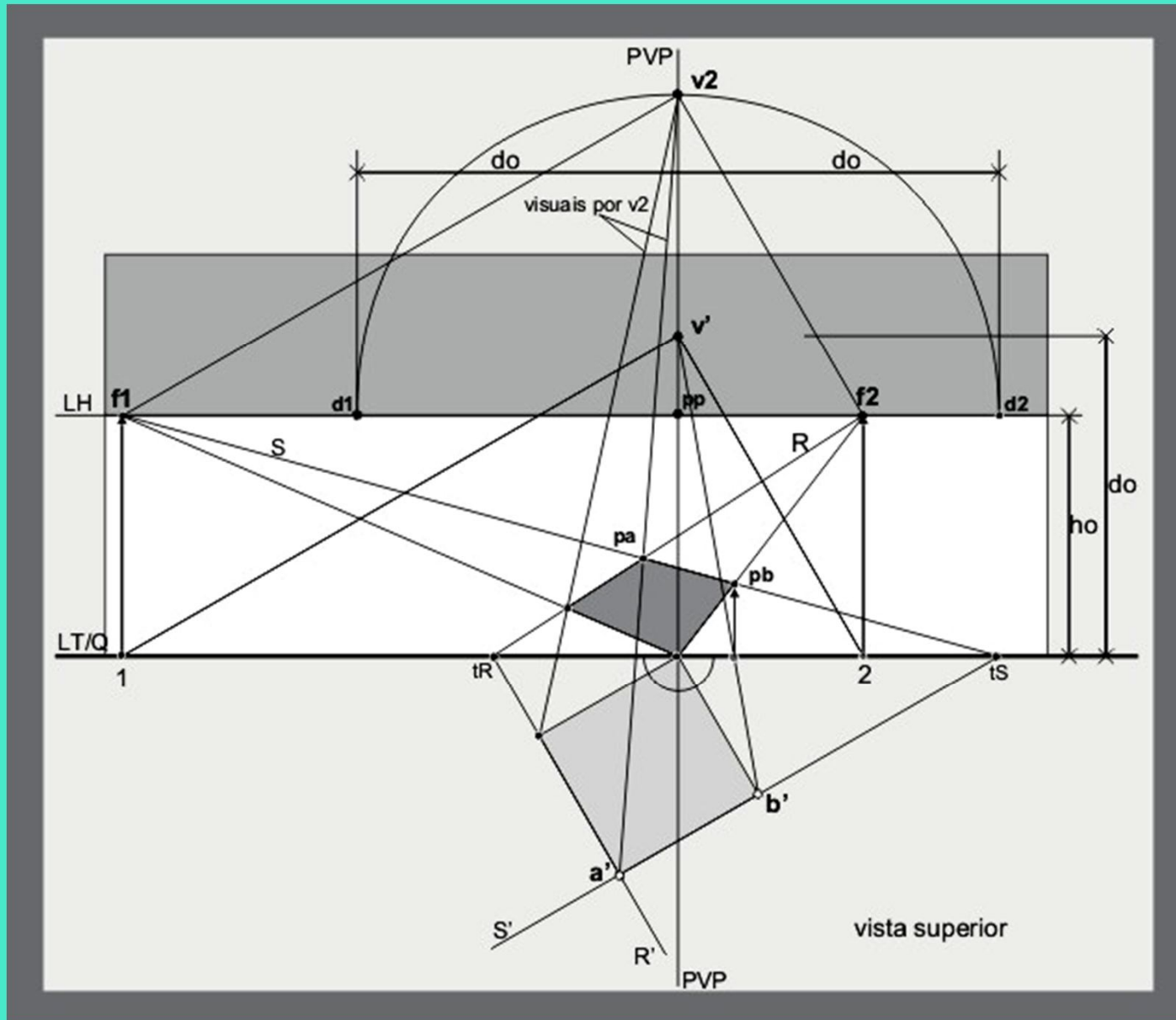

PERSPECTIVA OBLÍQUA

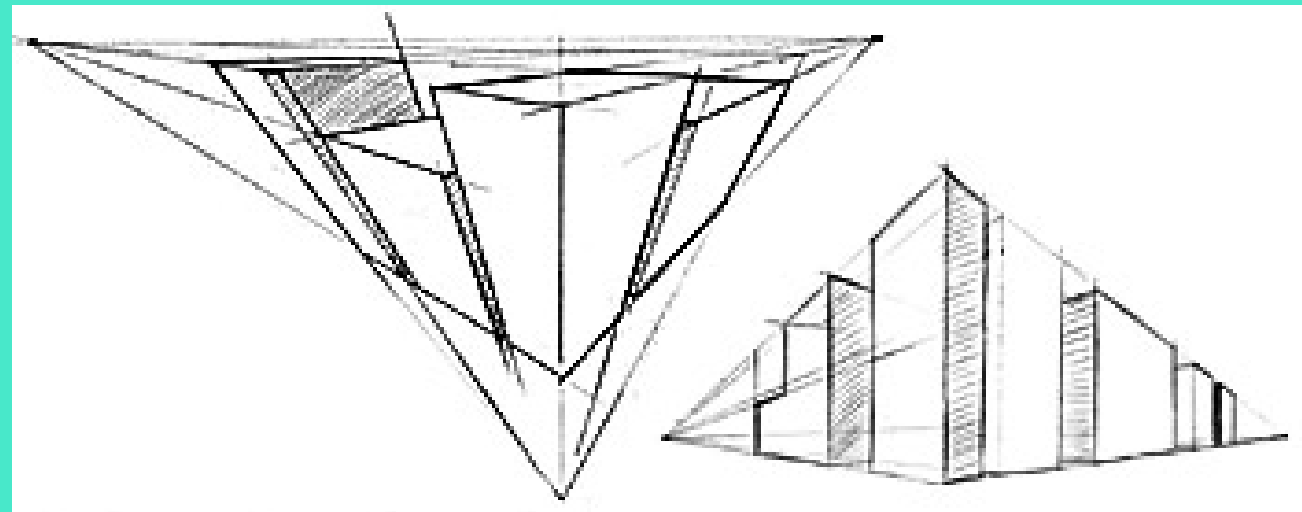
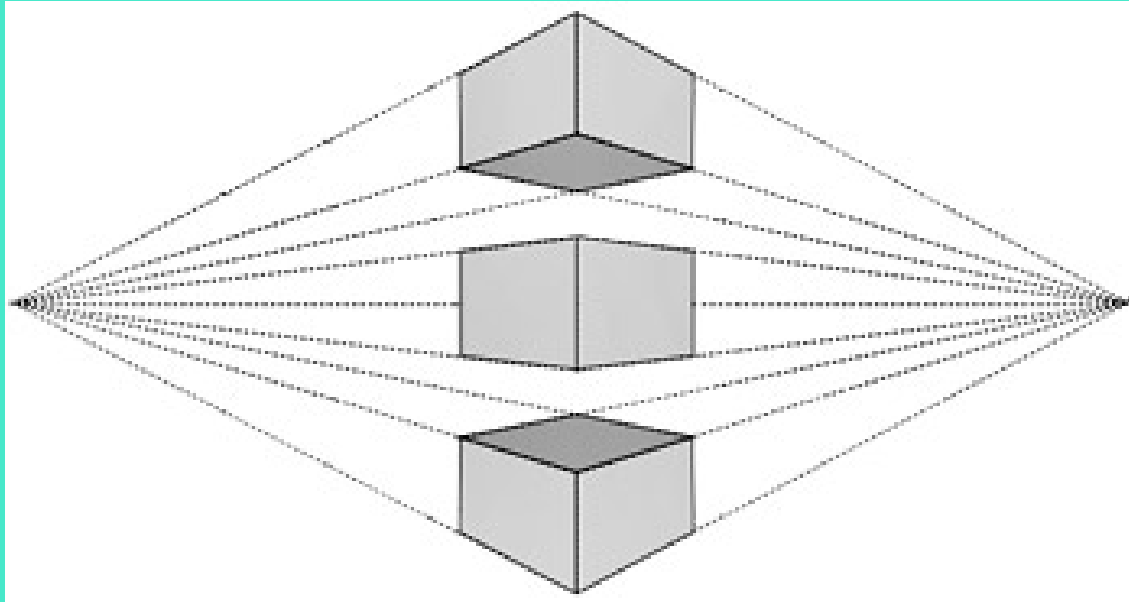

PERSPECTIVA OBLÍQUA



PERSPECTIVA OBLÍQUA



PERSPECTIVA OBLÍQUA

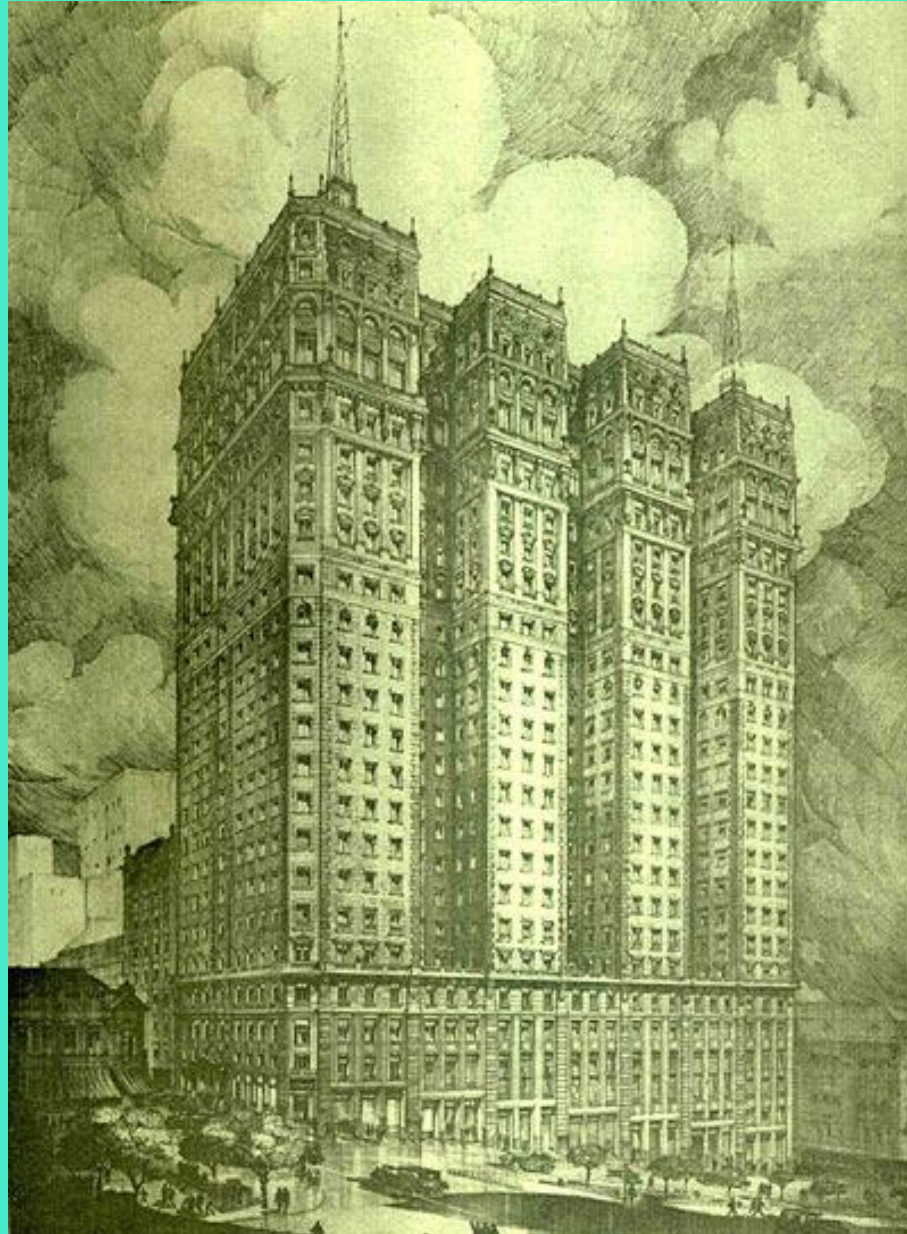

PERSPECTIVA OBLÍQUA

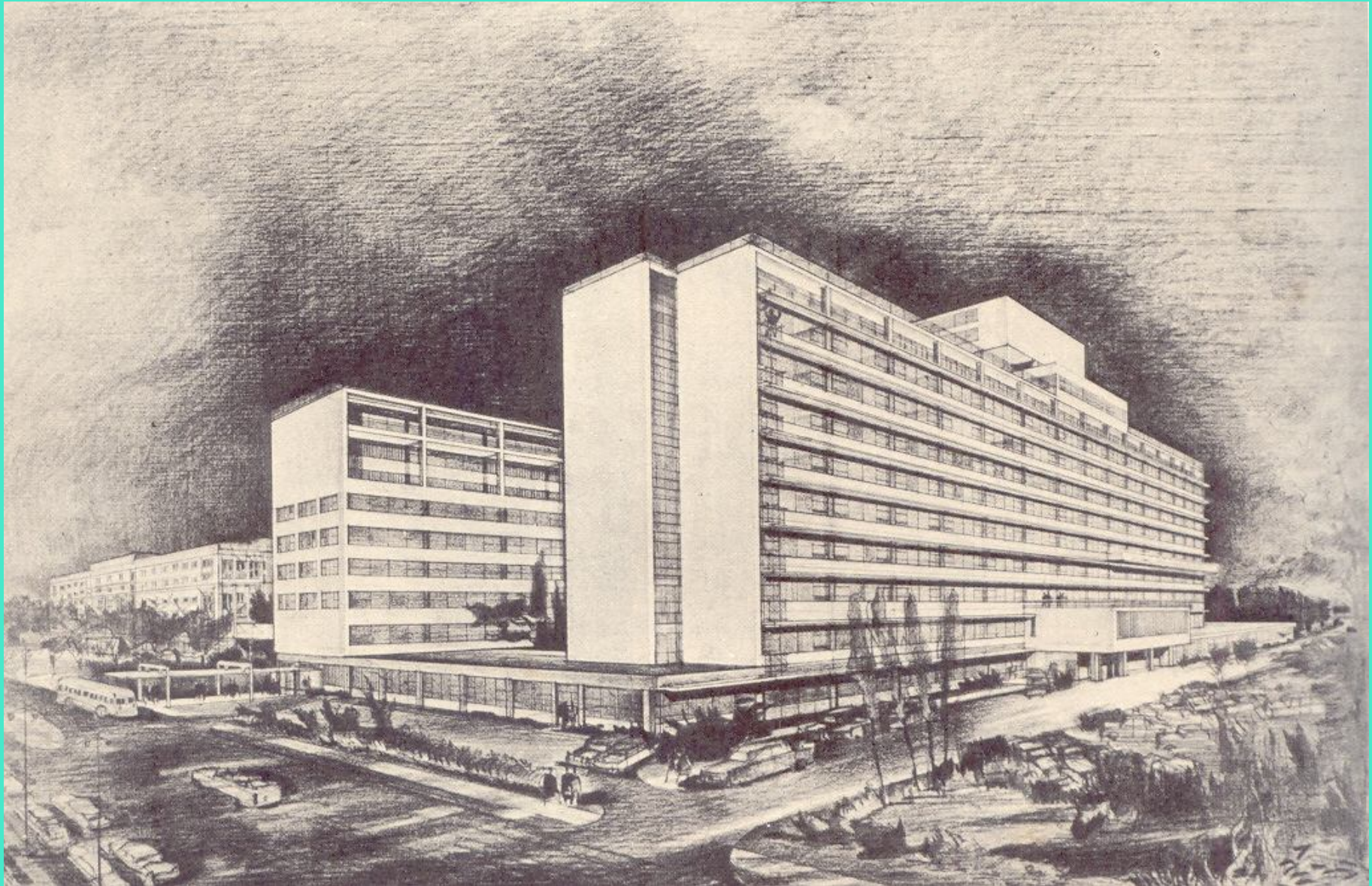

PERSPECTIVA OBLÍQUA

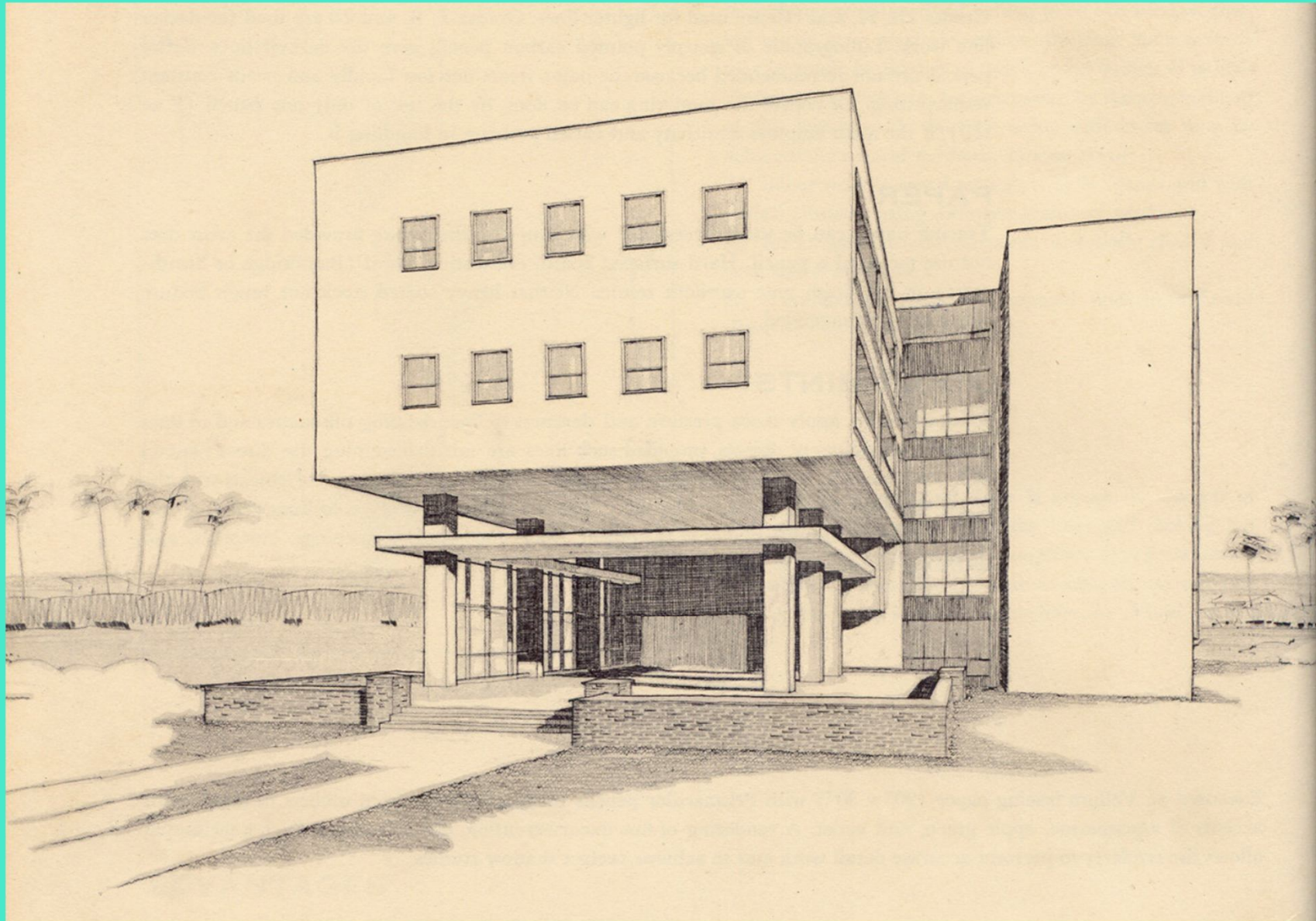

PERSPECTIVA OBLÍQUA



PERSPECTIVA OBLÍQUA

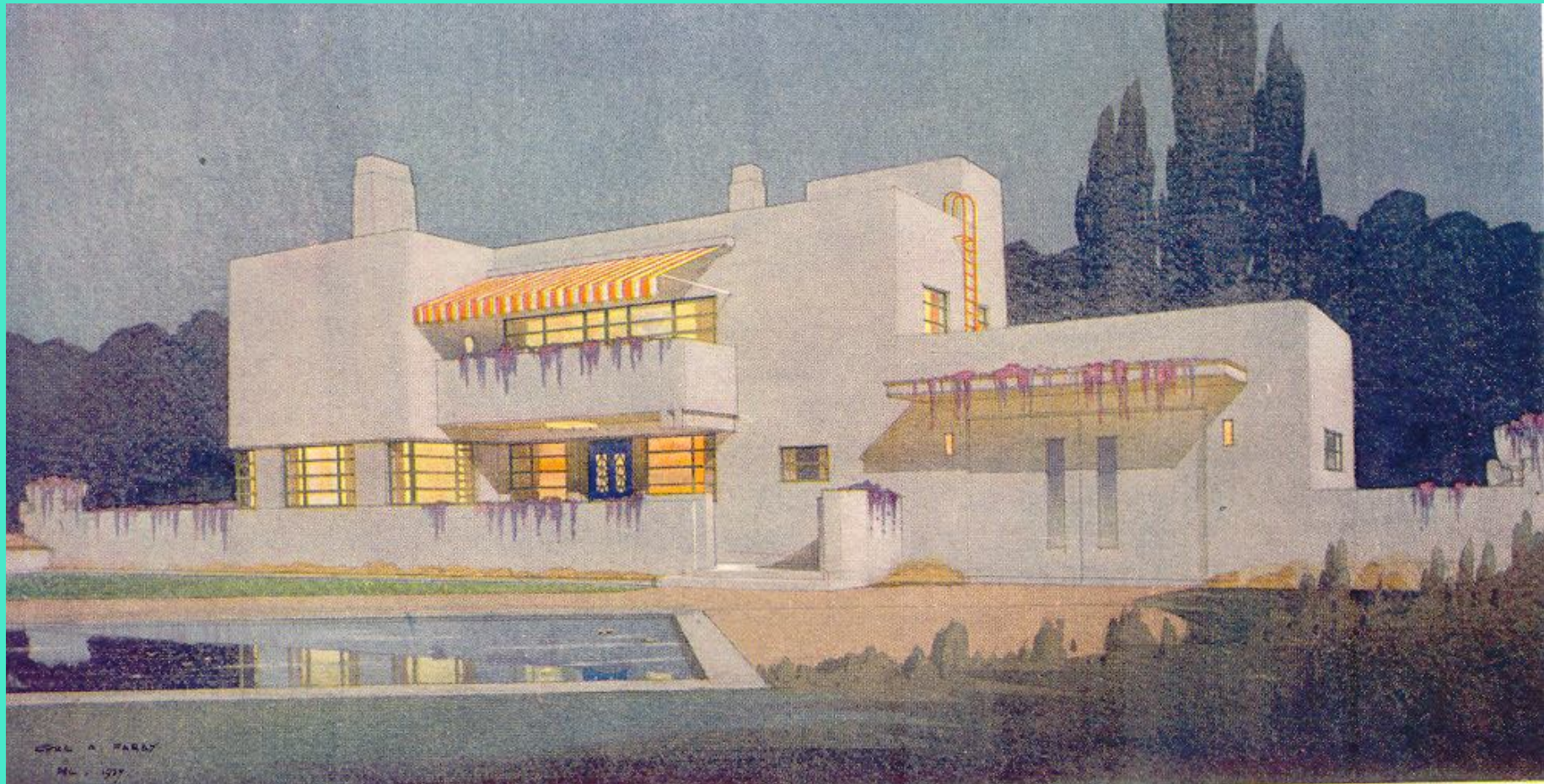

PERSPECTIVA OBLÍQUA



Figura 40. — TAMAÑO ORIGINAL 17 x 26 cm

PERSPECTIVA OBLÍQUA



PERSPECTIVA OBLÍQUA

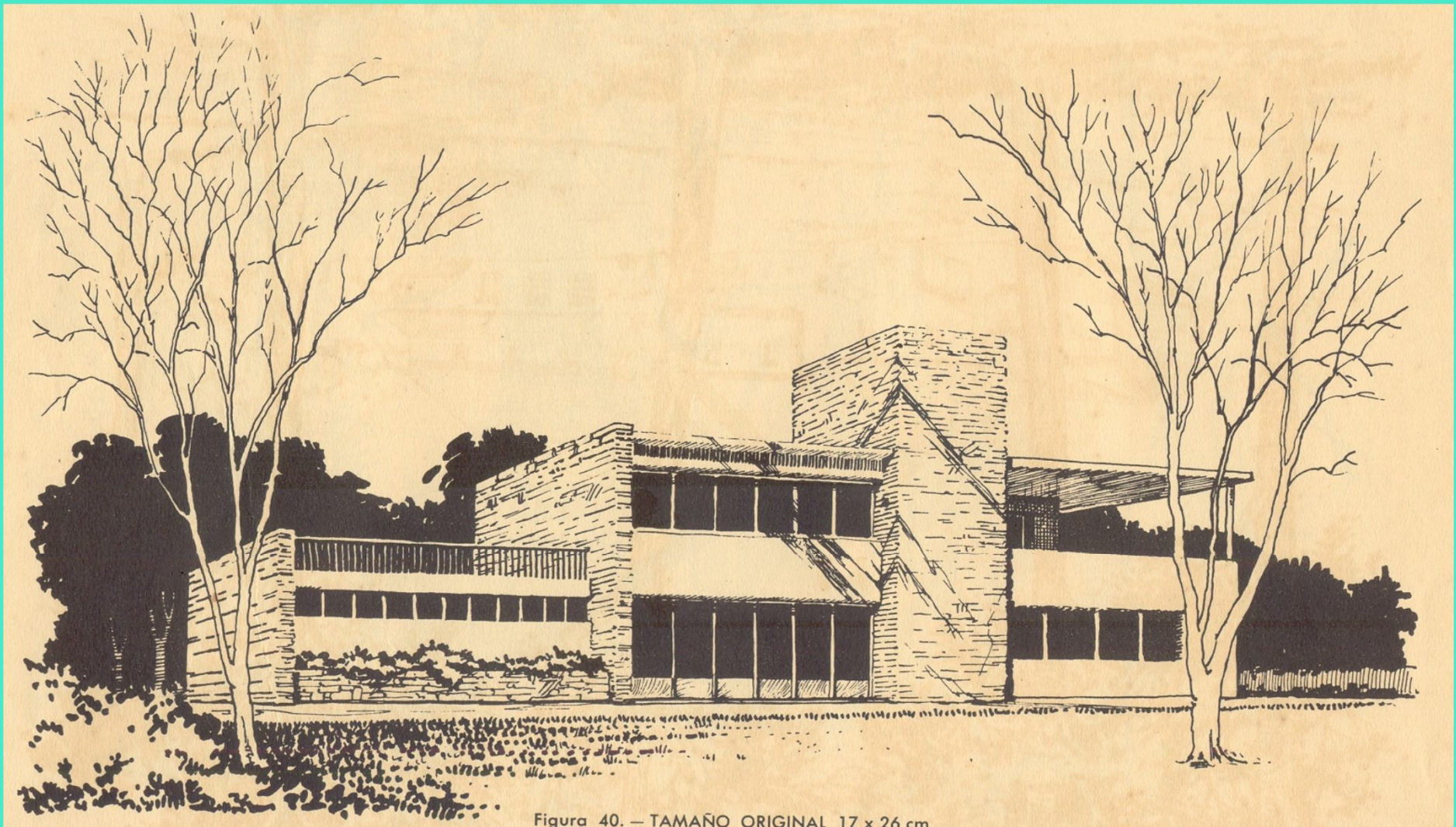
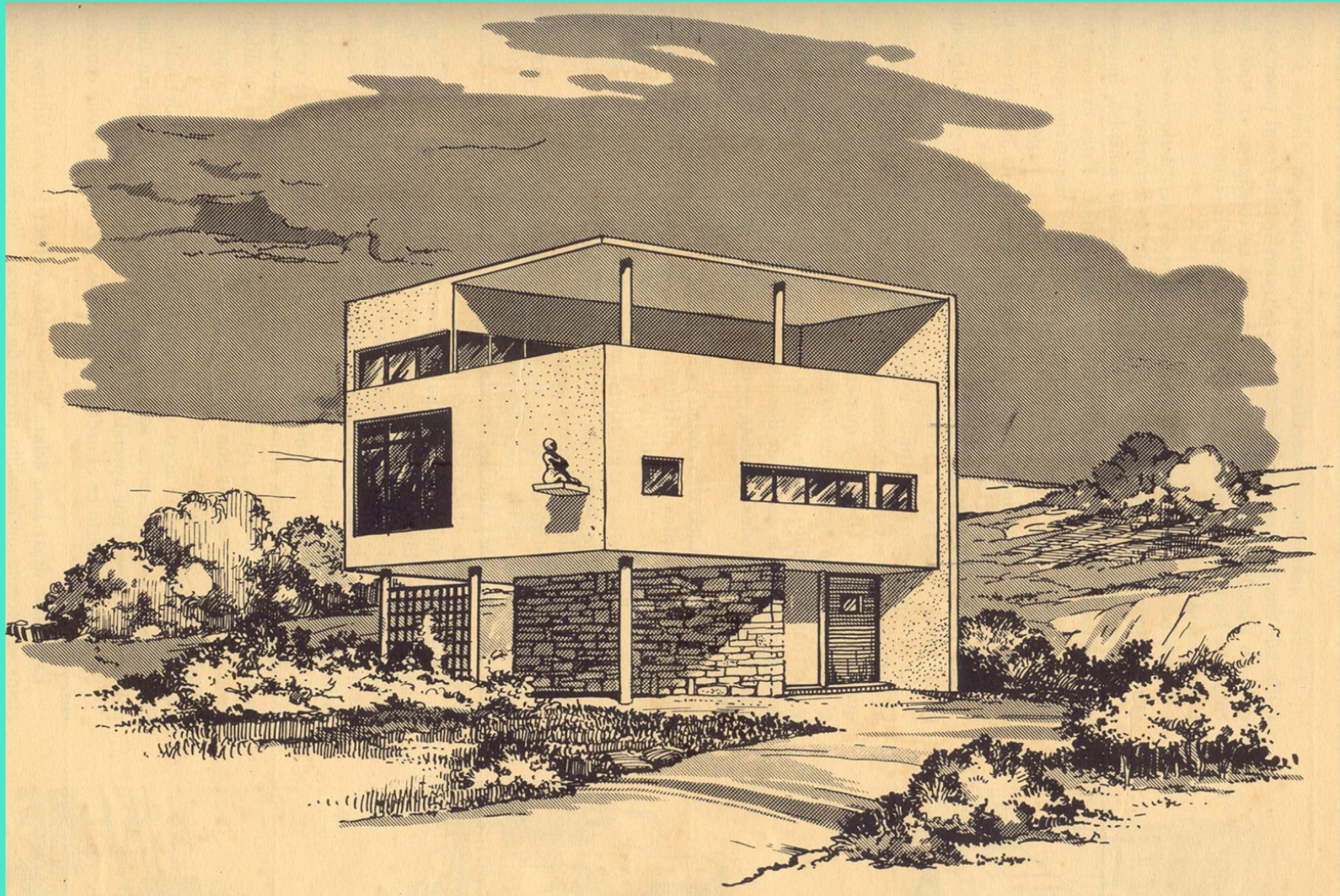

PERSPECTIVA OBLÍQUA



PERSPECTIVA OBLÍQUA

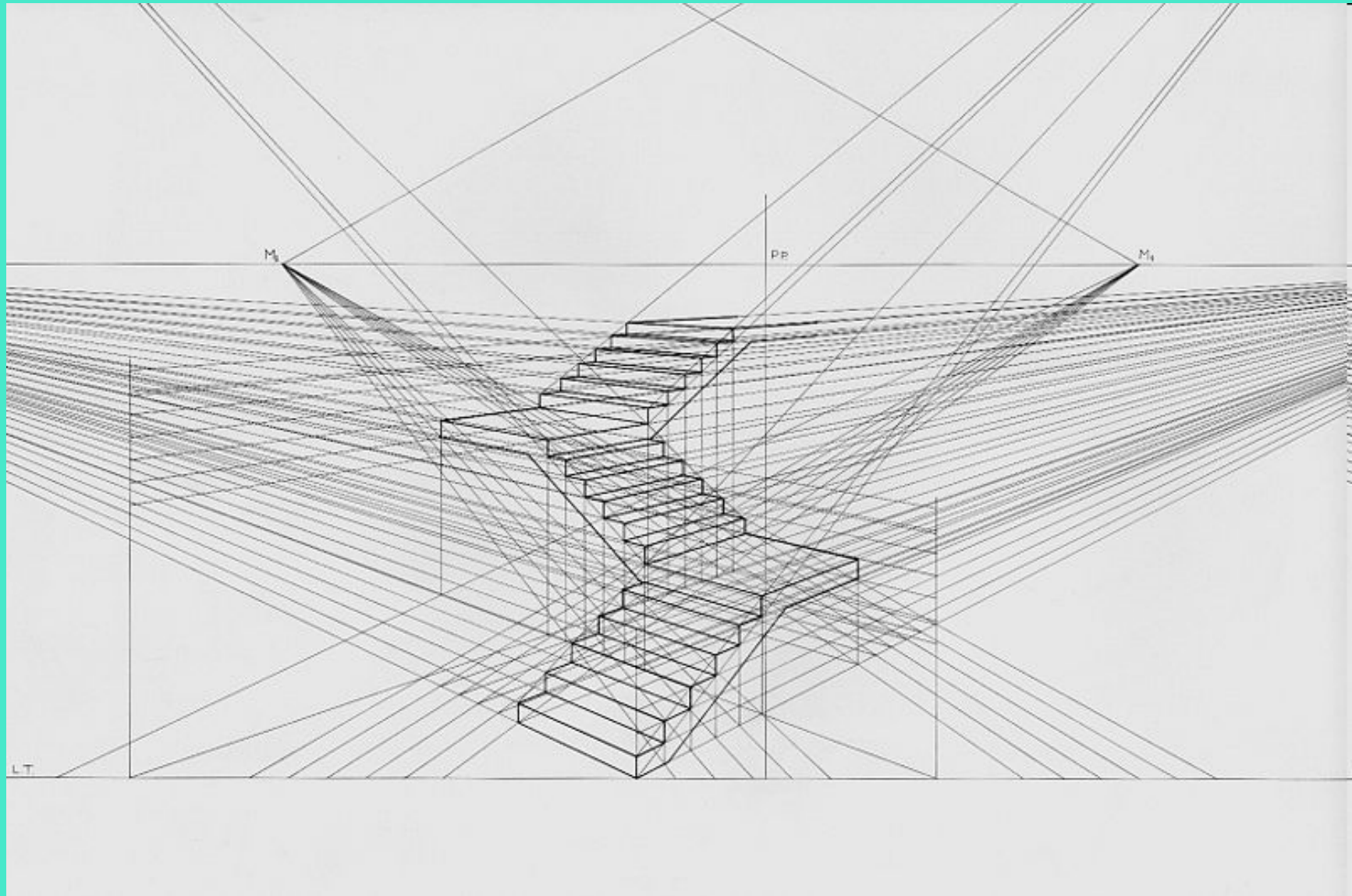

PERSPECTIVA OBLÍQUA

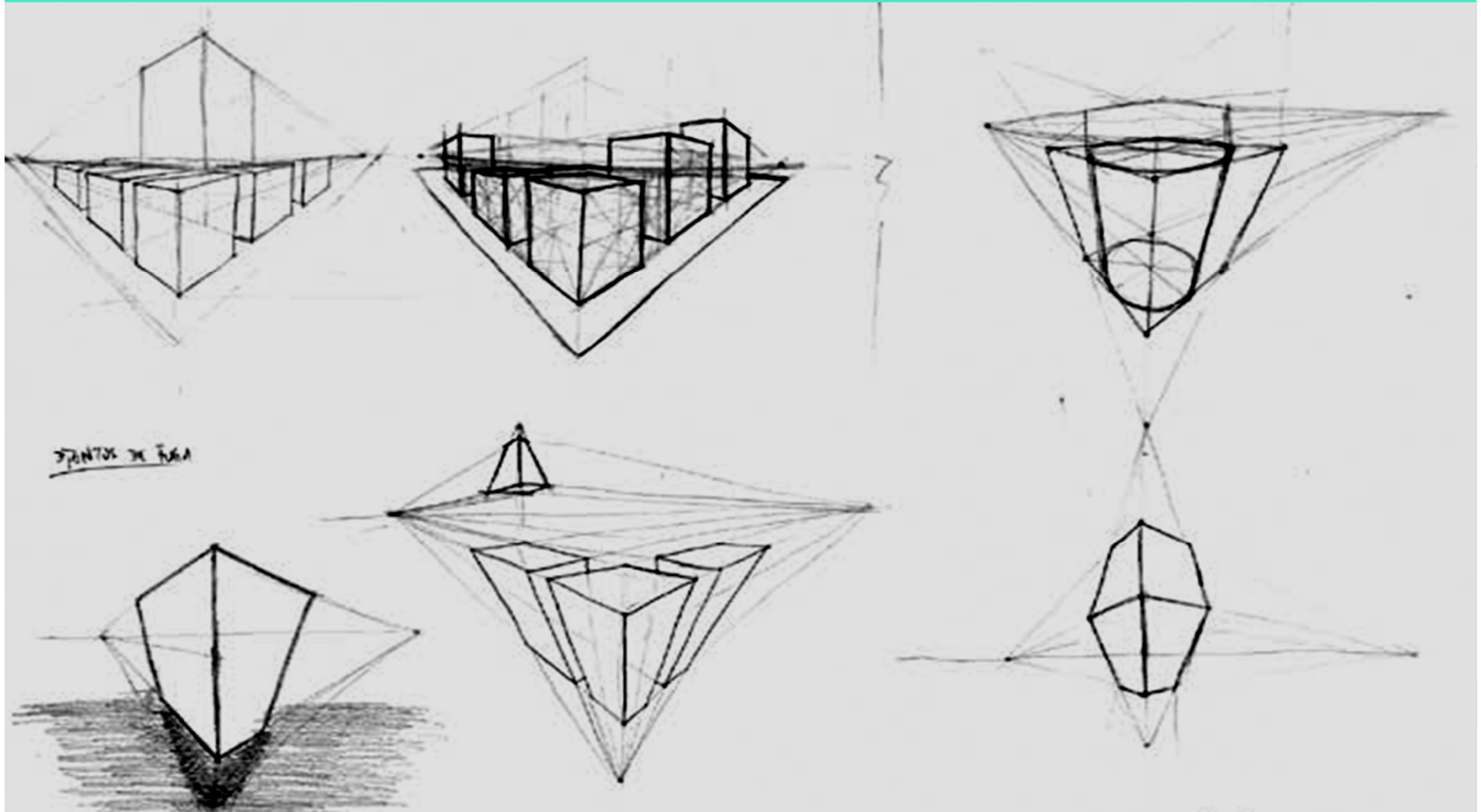

PERSPECTIVA OBLÍQUA



La Citta Nuova (The New City)
Antonio Sant'Elia, 1914

PERSPECTIVA OBLÍQUA

Cidade imaginária

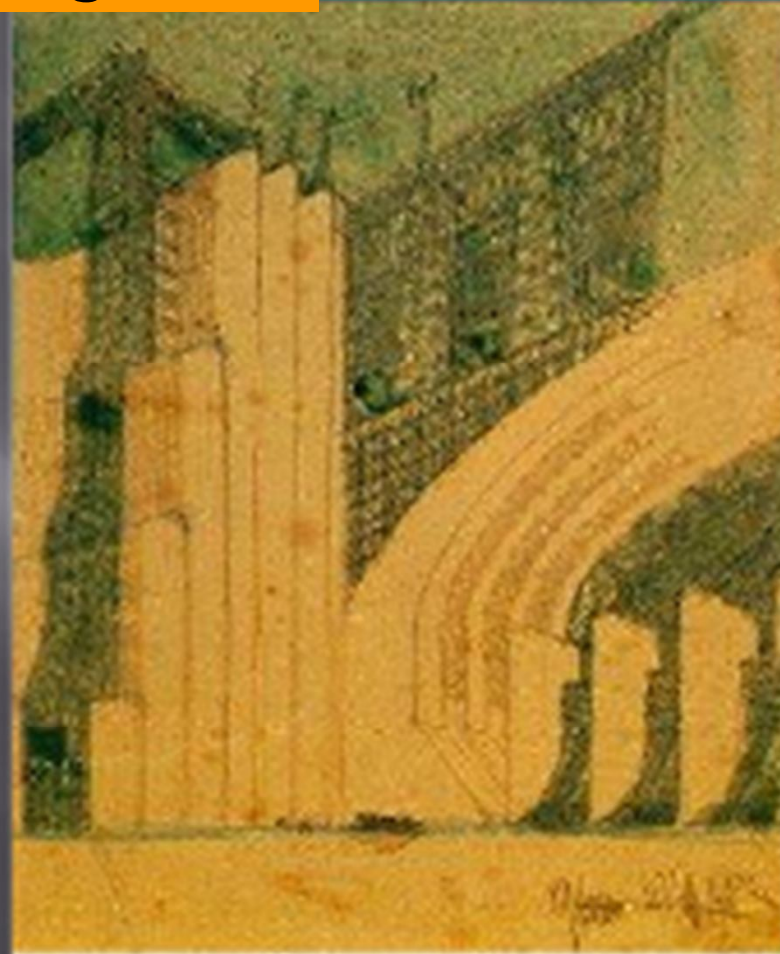

Power station
Antonio Sant'Elia. 27 October 1913
Musei Civici, Como

PERSPECTIVA OBLÍQUA

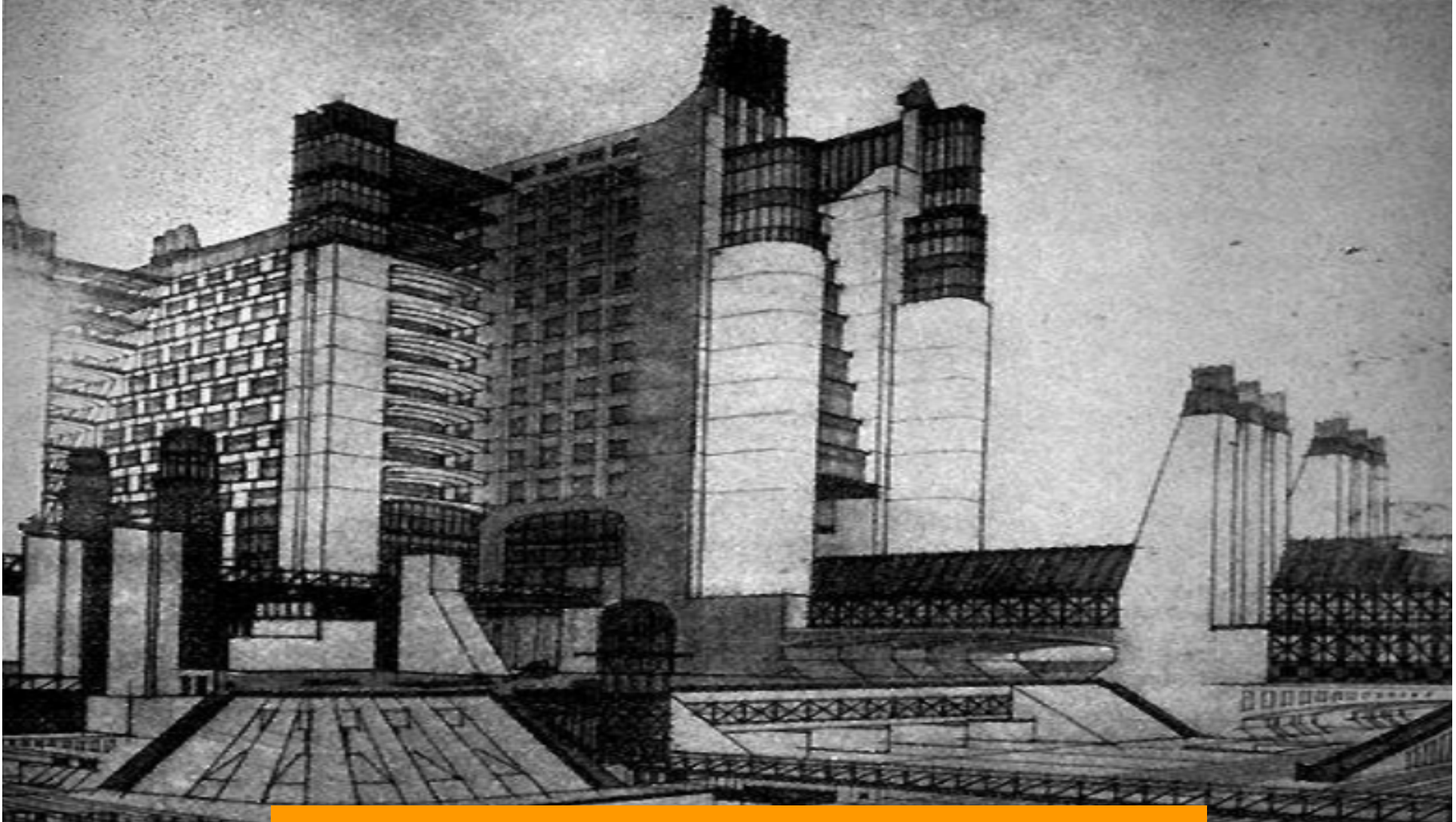

Central eléctrica Sant'Elia

PERSPECTIVA OBLÍQUA



Desenho de Sant' Elia

PERSPECTIVA OBLÍQUA

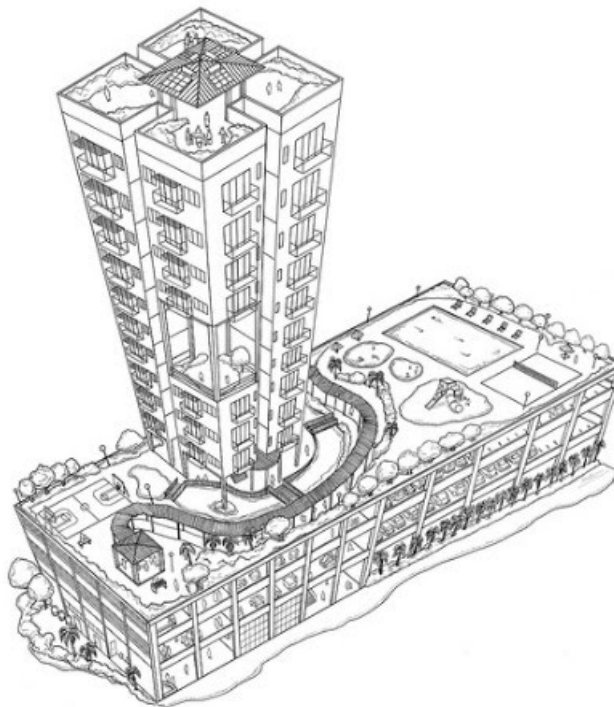

Vista de Lisboa desde o palácio do Marquês de Abrantes, primeira metade do século XVIII, óleo sobre tela – Landi.

PERSPECTIVA OBLÍQUA



O Palazzo Barberini , Carlo Maderno

PERSPECTIVA OBLÍQUA

FACULDADE ASSIS GURGACZ - MEIOS DE EXPRESSÃO: GEOMETRIA E PERSPECTIVA - PERSPECTIVA COM 2 PONTOS DE FUGA - PROFª DENISE SCHULER

<http://www.fag.edu.br/professores/deniseschuler/1%BA%20SEM%202009/GEOMETRIA%20E%20PERSPECTIVA/PERSPECTIVA%20%20PONTOS%20DE%20FUGA.pdf>

http://www.mat.uel.br/geometrica/php/gd_t/gd_2t.php

<http://ofdesenho.blogspot.com/2009/12/perspectiva-com-2-pontos-de-fuga.html>

http://2.bp.blogspot.com/_oXRLBJInJ6M/SyOILQMzCrI/AAAAAAAAA0A/DUgGOBnmQyU/s1600-h/foto-tres-pontos-fuga.jpg

<http://ofdesenho.blogspot.com/2009/12/perspectiva-com-3-pontos-de-fuga.html>

http://www.sobrearte.com.br/desenho/perspectiva/tipos_de_perspectiva.php

http://www.desenho.org/persp_conica2.php

http://www.ufmt.br/cuiabano/3_Disciplinas/Desenho_Tecnico/Perspectivas/Perspectivas.pdf